

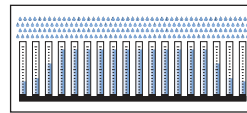

HIGH PRESSURE WASHING

Flat fan nozzles F series are designed for high-pressure washing applications. Their specially designed inner profile allows for even jet distribution, which results in effective and uniform cleaning action over the surface being processed. All nozzles are precisely machined and made of hardened stainless steel AISI 416.

- Thread specification: BSPT, NPT
- Typical applications
 - Car washing
 - High pressure washers
 - Industrial cleaning

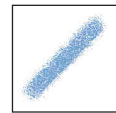
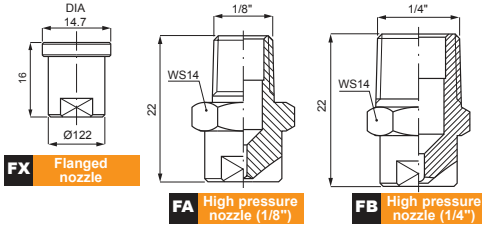

Nozzle type	Thread size
FA	1/8"
FB	1/4"
FX	Ø14.7

0°		15°			25°			40°			65°			US Gals	PNR Code	Capacity at different pressure values (l/min) (bar)							
FAA	FBA	FXA	FAB	FBB	FXB	FAD	FBD	FXD	FAL	FBL	FXL	FAR	FBR			FXR	20	30	50	70	100	150	200
•	•	•	•	•	•	•	•	•	•	•	•	•	•	•	015	1340	1.52	1.86	2.40	2.84	3.40	4.16	4.81
•	•	•	•	•	•	•	•	•	•	•	•	•	•	•	02	1460	2.06	2.52	3.25	3.85	4.60	5.63	6.51
•	•	•	•	•	•	•	•	•	•	•	•	•	•	•	025	1560	2.50	3.07	3.96	4.69	5.60	6.86	7.92
•	•	•	•	•	•	•	•	•	•	•	•	•	•	•	03	1686	3.07	3.76	4.85	5.74	6.86	8.40	9.70
•	•	•	•	•	•	•	•	•	•	•	•	•	•	•	035	1812	3.63	4.45	5.74	6.79	8.12	9.94	11.5
•	•	•	•	•	•	•	•	•	•	•	•	•	•	•	04	1930	4.16	5.09	6.58	7.78	9.30	11.4	13.2
•	•	•	•	•	•	•	•	•	•	•	•	•	•	•	045	2103	4.61	5.64	7.28	8.62	10.3	12.6	14.6
•	•	•	•	•	•	•	•	•	•	•	•	•	•	•	05	2116	5.19	6.35	8.20	9.71	11.6	14.2	16.4
•	•	•	•	•	•	•	•	•	•	•	•	•	•	•	055	2126	5.63	6.90	8.91	10.5	12.6	15.4	17.8
•	•	•	•	•	•	•	•	•	•	•	•	•	•	•	06	2138	6.17	7.56	9.76	11.5	13.8	16.9	19.5
•	•	•	•	•	•	•	•	•	•	•	•	•	•	•	065	2149	6.66	8.16	10.5	12.5	14.9	18.2	21.1
•	•	•	•	•	•	•	•	•	•	•	•	•	•	•	07	2160	7.16	8.76	11.3	13.4	16.0	19.6	22.6
•	•	•	•	•	•	•	•	•	•	•	•	•	•	•	075	2170	7.60	9.31	12.0	14.2	17.0	20.8	24.0
•	•	•	•	•	•	•	•	•	•	•	•	•	•	•	08	2181	8.09	9.91	12.8	15.1	18.1	22.2	25.6
•	•	•	•	•	•	•	•	•	•	•	•	•	•	•	085	2192	8.59	10.5	13.6	16.1	19.2	23.5	27.2
•	•	•	•	•	•	•	•	•	•	•	•	•	•	•	09	2204	9.12	11.2	14.4	17.1	20.4	25.0	28.8
•	•	•	•	•	•	•	•	•	•	•	•	•	•	•	095	2226	10.1	12.4	16.0	18.9	22.6	27.7	32.0
•	•	•	•	•	•	•	•	•	•	•	•	•	•	•	10	2230	10.3	12.6	16.3	19.2	23.0	28.2	32.5
•	•	•	•	•	•	•	•	•	•	•	•	•	•	•	11	2248	11.1	13.6	17.5	20.7	24.8	30.4	35.1
•	•	•	•	•	•	•	•	•	•	•	•	•	•	•	12	2272	12.2	14.9	19.2	22.8	27.2	33.3	38.5
•	•	•	•	•	•	•	•	•	•	•	•	•	•	•	12.5	2280	12.5	15.3	19.8	23.4	28.0	34.3	39.6
•	•	•	•	•	•	•	•	•	•	•	•	•	•	•	13	2296	13.2	16.2	20.9	24.8	29.6	36.3	41.9
•	•	•	•	•	•	•	•	•	•	•	•	•	•	•	14	2320	14.3	17.5	22.6	26.8	32.0	39.2	45.3
•	•	•	•	•	•	•	•	•	•	•	•	•	•	•	15	2341	15.2	18.7	24.1	28.5	34.1	41.8	48.2
•	•	•	•	•	•	•	•	•	•	•	•	•	•	•	16	2360	16.1	19.7	25.5	30.1	36.0	44.1	50.9
•	•	•	•	•	•	•	•	•	•	•	•	•	•	•	18	2410	18.3	22.5	29.0	34.3	41.0	50.2	58.0
•	•	•	•	•	•	•	•	•	•	•	•	•	•	•	20	2456	20.4	25.0	32.2	38.2	45.6	55.8	64.5
•	•	•	•	•	•	•	•	•	•	•	•	•	•	•	25	2567	25.4	31.1	40.1	47.4	56.7	69.4	80.2
•	•	•	•	•	•	•	•	•	•	•	•	•	•	•	30	2682	30.5	37.4	48.2	57.1	68.2	83.5	96.4
•	•	•	•	•	•	•	•	•	•	•	•	•	•	•	35	2800	35.8	43.8	56.6	66.9	80.0	98.0	113
•	•	•	•	•	•	•	•	•	•	•	•	•	•	•	40	2970	43.4	53.1	68.6	81.2	97.0	119	137
•	•	•	•	•	•	•	•	•	•	•	•	•	•	•	50	3113	50.5	61.9	79.9	94.5	113	138	160
•	•	•	•	•	•	•	•	•	•	•	•	•	•	•	60	3135	60.4	73.9	95.5	113	135	165	191

HOW TO MAKE UP THE NOZZLE CODE

EX.: FAA 1340 C2

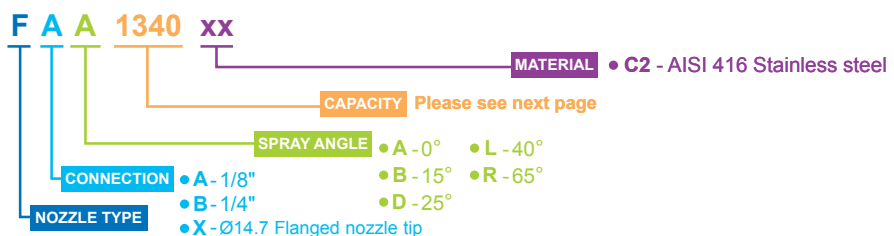

OUTER DIMENSION OF F TYPE NOZZLES AND FX NOZZLE TIPS (CODE)

The table on the right shows the correspondence between the nominal capacity in US Gallons per minute at 40 psi, which is commonly used to identify high pressure washing nozzles and the PNR capacity code at 100 bar. For the convenience of worldwide use, all nozzles are US coding system.

For example:

FBA 1686 C2 (PNR code) nozzle will be codified as **00/03** (US Gallons) with a spray angle 0° and capacity 0.3 Gals/min at a pressure of 40 psi.

FBD 2116 C2 (PNR code) nozzle will be codified as **25/05** (US Gallons) with a spray angle 25° and capacity 0.5 Gals/min at a pressure of 40 psi. (see below)

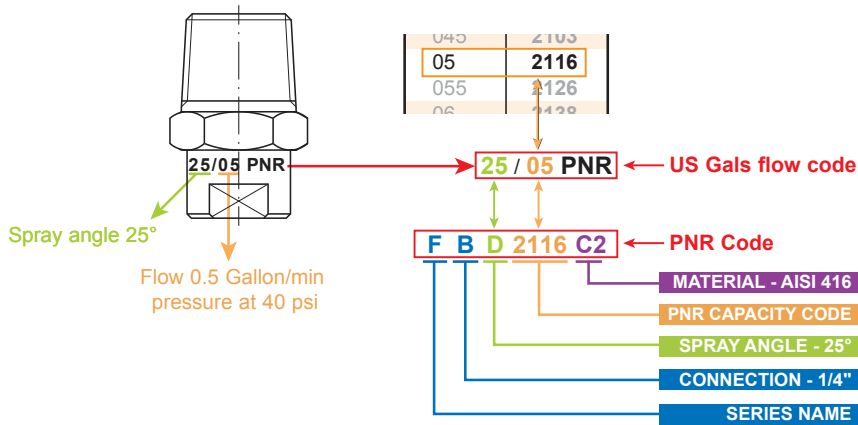

US Gals	PNR Code
015	1340
02	1460
025	1560
03	1686
035	1812
04	1930
045	2103
05	2116
055	2126
065	2149
07	2160
075	2170
08	2181
085	2192
09	2204
095	2226
10	2230
11	2248
12	2272
12.5	2280
13	2296
14	2320
15	2341
16	2360
18	2410
20	2456
25	2567
30	2682
35	2800
40	2970
50	3113
60	3135

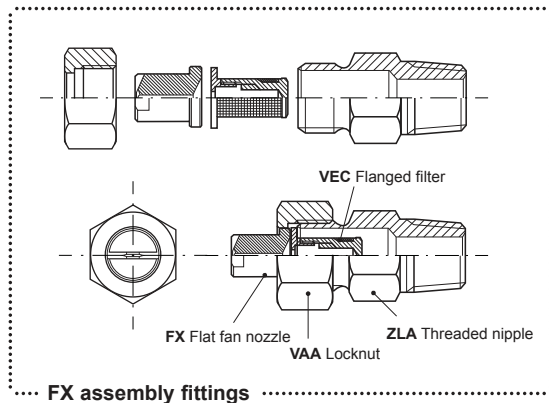

HIGH PRESSURE WASHING ACCESSORIES

We have all kinds of washing guns (low/medium/high/superhigh pressure) and accessories for various washing applications and environments. We will help you to chose the best solution for your needs.



UMW 0010 D4
High pressure gun
(P.95)



UMW 0020 D4
High pressure gun
(P.95)

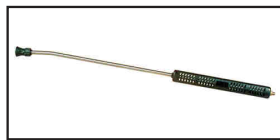

UMW 0030 B3
High pressure lance
(P.96)



UMW 0045 B3
High pressure lance
(P.96)



UMU J/I
Auto-rewind reels
(P.102)

OPTIONAL ELEMENT- FLOW STRAIGHTENER

Flow straighteners improve spray jet efficiency by straightening the liquid path to minimize turbulence and produce swirl-free, even, stable and straight-run flows. All PNR nozzles are ready to embed a flow straightener.

These items can be supplied separately on request.

