



aerospace
climate control
electromechanical
filtration
fluid & gas handling
hydraulics
pneumatics
process control
sealing & shielding



P3Y Series Air preparation system

3/4" & 1" Body Ported, 1 1/4" & 1 1/2" with Port Blocks

Catalogue no. PDE2631TCUK October 2021



ENGINEERING YOUR SUCCESS.

Table of Contents

The System.....	3
Recommended wall mountings	4
Popular combinations	5
Filters	6 - 7
Dust Filters	8 - 9
Coalescing filters	10 - 11
Adsorber filters	12 - 13
Regulators	14 - 15
Filter regulators	16 - 17
Lubricators	18 - 19
Proportional pressure regulator	20 - 21
Combined soft start dump valve	22 - 23
Remote operated dump valve	22 - 23
Soft Start valve	24 - 25
Pilot operated regulator	26 - 27
Modular ball valve	28
Modular manifold	29
Optional port block kits	30
Solenoid Operators	31
Solenoid Connectors	32
Accessories	33



WARNING

FAILURE OR IMPROPER SELECTION OR IMPROPER USE OF THE PRODUCTS AND/OR SYSTEMS DESCRIBED HEREIN OR RELATED ITEMS CAN CAUSE DEATH, PERSONAL INJURY AND PROPERTY DAMAGE.

This document and other information from Parker Hannifin Corporation, its subsidiaries and authorized distributors provide product and/or system options for further investigation by users having technical expertise. It is important that you analyze all aspects of your application and review the information concerning the product or system in the current product catalog. Due to the variety of operating conditions and applications for these products or systems, the user, through its own analysis and testing, is solely responsible for making the final selection of the products and systems and assuring that all performance, safety and warning requirements of the application are met. The products described herein, including without limitation, product features, specifications, designs, availability and pricing, are subject to change by Parker Hannifin Corporation and its subsidiaries at any time without notice.

SALE CONDITIONS

The items described in this document are available for sale by Parker Hannifin Corporation, its subsidiaries or its authorized distributors. Any sale contract entered into by Parker will be governed by the provisions stated in Parker's standard terms and conditions of sale (copy available upon request).

P3Y series modular air preparation system

The System

The P3Y system allows units to be connected together, without the use of pipe connectors, saving space; providing constant mounting centres; whilst maintaining a modern aesthetically pleasing appearance.

The P3Y Filters are specially designed to efficiently filter out rust, dirt, moisture and other impurities from compressed air lines. Operation is fully automatic with a minimum of pressure drop. Coalescing filters and adsorber filters for high purity air are also included in the P3Y series.

The P3Y Regulators are designed to provide quick response and accurate pressure regulation for the most demanding hi-flow industrial applications. The rolling diaphragm was designed for long trouble-free operation and will not rupture or tear under high cycle or other demanding applications.

The P3Y mist lubricators are designed to provide lubrication for many general purpose applications in a pneumatic system.

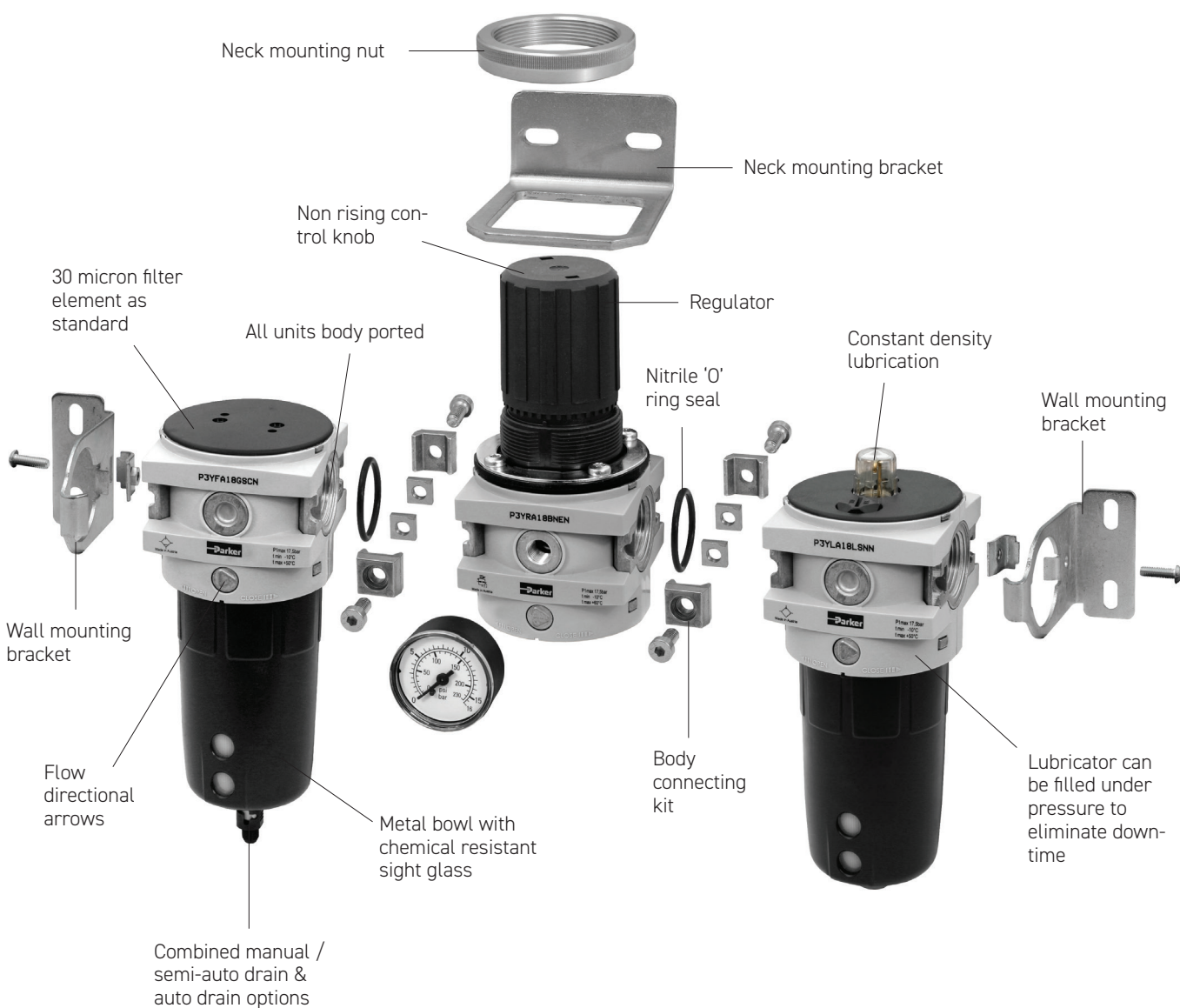

Recommended Wall Mounting Configurations

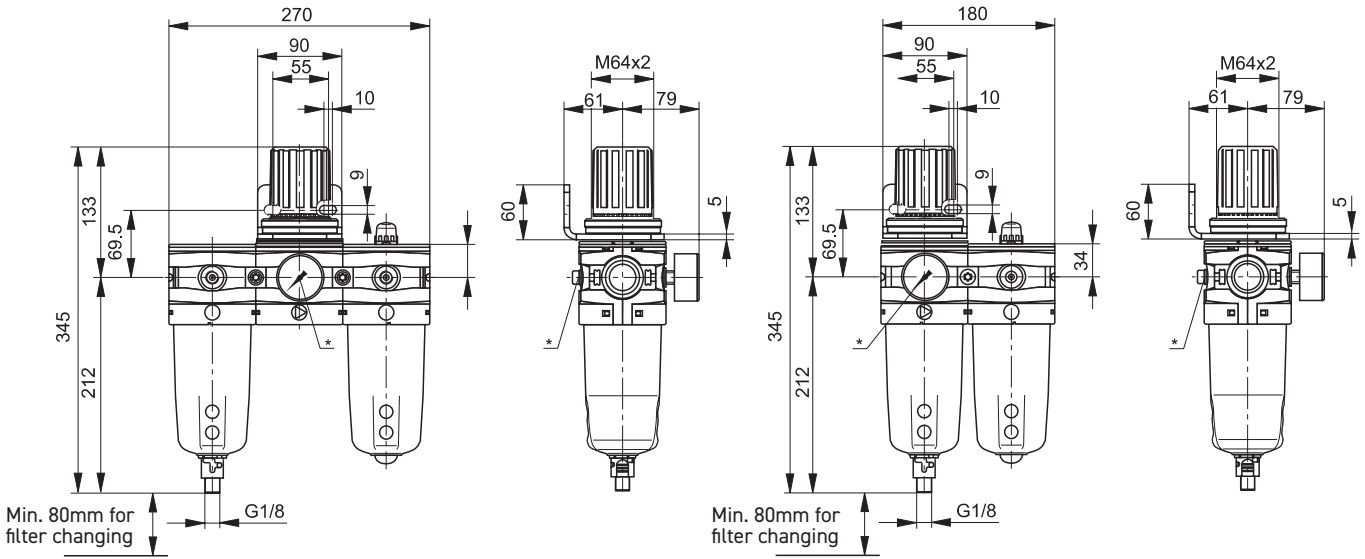

* Gauge port 1/4"

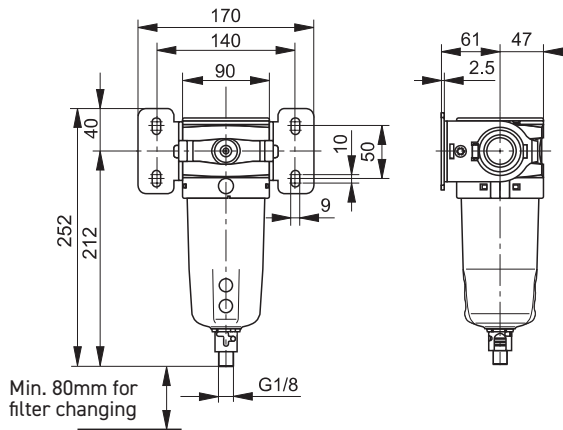

P3Y Series air preparation system

Popular Combinations

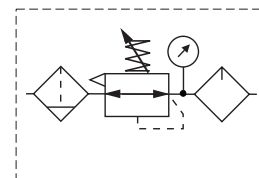

Filter + Regulator + Lubricator Combinations 30 micron element, 12 bar Regulator + Gauge and Wall Mounting Bracket

Port size	Combined Manual/Semi-Auto Drain	Flow dm ³ /s	Weight (kg)	Auto Drain	Flow dm ³ /s	Weight (kg)
G ³ / ₄	P3YCB16SGCNFLNF	91	3.3	P3YCB16SGANFLNF	91	3.3
G1	P3YCB18SGCNFLNF	174	3.3	P3YCB18SGANFLNF	174	3.3

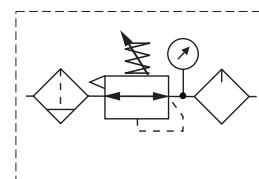

Filter/Regulator + Lubricator Combinations 30 micron element, 12 bar Regulator + Gauge and Wall Mounting Bracket

Port size	Combined Manual/Semi-Auto Drain	Flow dm ³ /s	Weight (kg)	Auto Drain	Flow dm ³ /s	Weight (kg)
G ³ / ₄	P3YCA16SGCNFLNF	101	2.8	P3YCA16SGANFLNF	101	2.8
G1	P3YCA18SGCNFLNF	168	2.8	P3YCA18SGANFLNF	168	2.8

* Flow measured with 10 bar inlet pressure, 6.3 bar set pressure, 1 bar pressure drop.

Options:

P3Y	C				S			N		LNLF	
Filter/Reg + Lub	A	BSPP (G)	1	3/4"	6	5 Micron	E	Combined Manual/Semi Auto Drain	C	0 - 12 bar with gauge	F
Filter + Reg + Lub	B	NPT*		1"	8	30 Micron	G	Auto Drain	A	0 - 16 bar with gauge	J

*See Optional Port Block Kits

Technical Information

Fluid:	Compressed air
Maximum inlet pressure*:	17.5 bar
Temperature range*:	
Auto drain :	-10°C to +60°C
Combined drain :	-40°C to +60°C
Particle removal:	5 & 30 micron
Typical flow with 30µm element 6,3 bar inlet pressure and 0.5 bar pressure drop:	119 dm ³ /s
Manual/Semi-auto drain:	Closed at 0.8 bar G1/8 thread
Auto drain:	
bowl pressure to close drain	0.8 bar
Operating range	0.8 to 17.5 bar
manual override facility (depress pin)	∅ 10mm brass connection
Bowl sump capacity:	130 cm ³

* Air supply must be dry enough to avoid ice formation at temperatures below +2°C

Dimensions (mm)

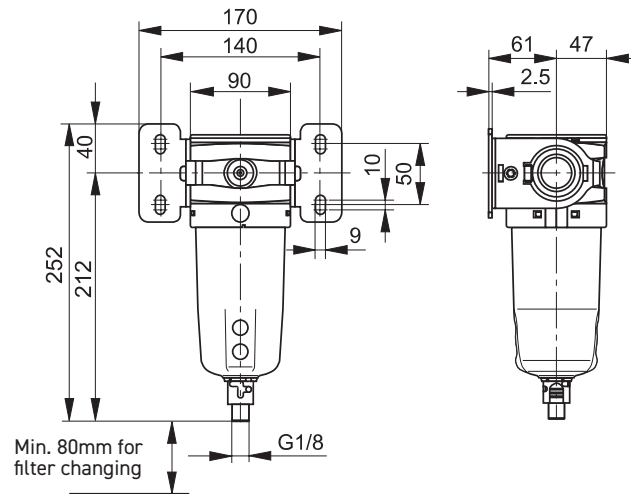

Service kits

Description	Order code
5 micron element kit	P3YKA00ESE
30 micron element kit	P3YKA00ESG
Bowl kit with combined manual/semi auto drain	P3YKA00BSC
Bowl kit with auto drain	P3YKA00BSA

Material Specification

Body:	Aluminium
Sight glass:	Polypropylene
Body cover:	ABS
Element:	Sintered P.E.
Seals:	Nitrile NBR
Drains:	Manual / Semi-auto: Acetal
	Automatic: PA / Brass connection

Flow characteristics

(3/4") 30 Micron Filter

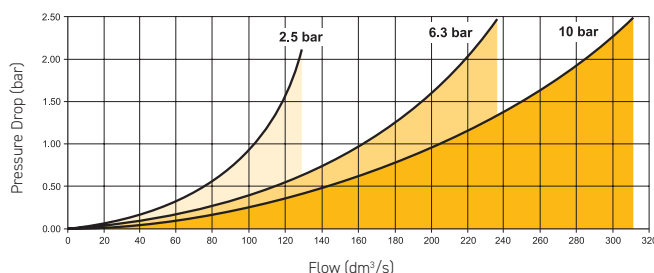

(1") 30 Micron Filter

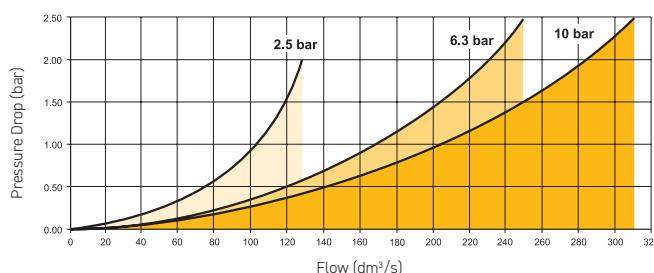

(3/4") 5 Micron Filter

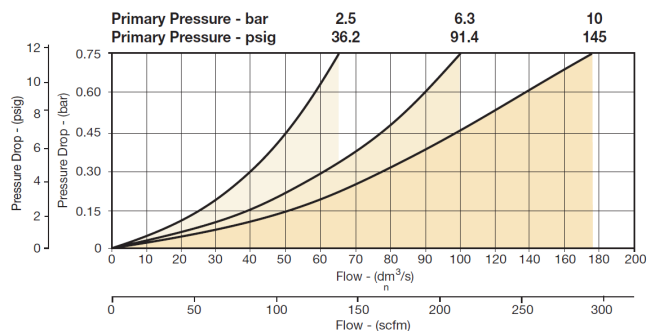

(1") 5 Micron Filter

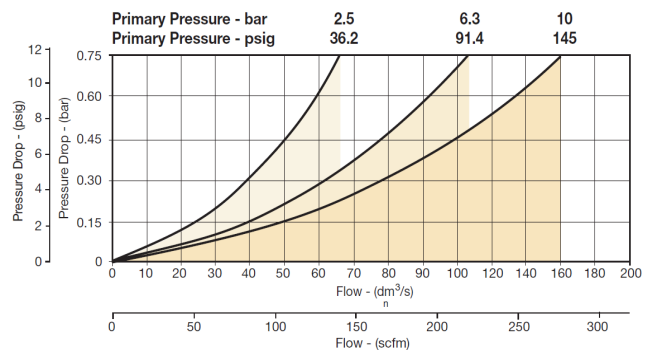

Particulate Filters



- Extended dust filter element provides greater filtration surface area.
- Integral 3/4 or 1" ports (BSPP & NPT)
- Removes dust particles
- Dust free air for critical applications, such as air gauging, pneumatic instrumentation and control

Note: To optimise the life of the dust 1µm element, it is advisable to install a P3YFA pre-filter with a 5 or 30 micron element upstream of the coalescing filter.

Options:

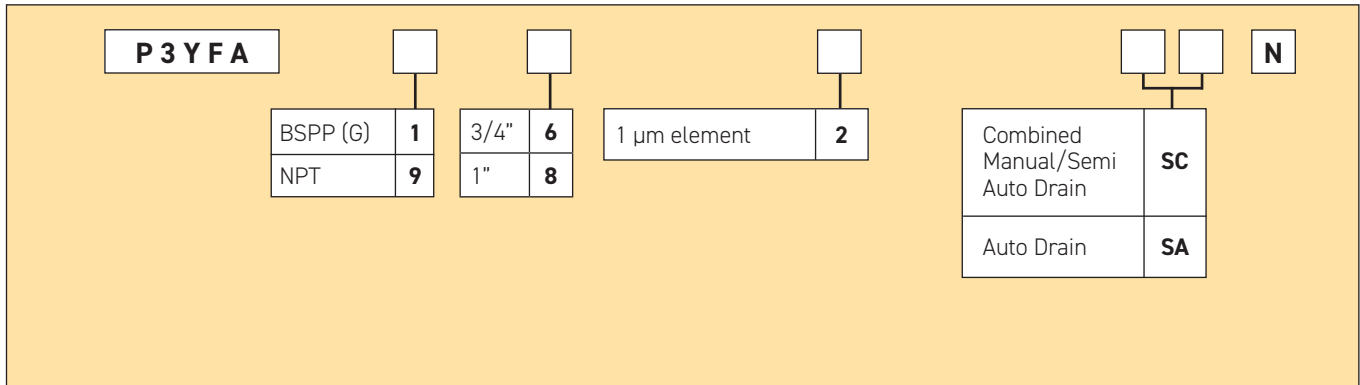

Port size	Description	Order Code	Flow dm ³ /s *	Max bar	Min temp °C	Max temp °C	Bowl capacity cm ³	Height mm	Width mm	Depth mm	Weight kg
3/4	Dust Filter 1µm, Combined manual/semi auto drain	P3YFA162SCN	137	17.5	-10	60	130	360	90	94	1.6
3/4	Dust Filter 1µm, auto drain	P3YFA162SAN	137	17.5	-10	60	130	360	90	94	1.6
1"	Dust Filter 1µm, Combined manual/semi auto drain	P3YFA182SCN	145	17.5	-10	60	130	360	90	94	1.6
1"	Dust Filter 1µm, auto drain	P3YFA182SAN	145	17.5	-10	60	130	360	90	94	1.6

* flow with 6,3 bar inlet pressure and 0,5 pressure drop

Technical Information

Fluid:	Compressed air
Maximum inlet pressure*:	17.5 bar
Temperature range*:	-10°C to +60°C
Typical flow element @ 6,3 bar inlet pressure and 5 bar pressure drop:	145 dm ³ /s
Manual/Semi-auto drain:	Bowl pressure to close drain 0.8 bar G1/8" thread
Auto drain: bowl pressure to close drain Operating range manual override facility (depress pin)	0.8 bar 0.8 to 17.5 bar Ø 10mm brass connection
Bowl sump capacity:	130 cm ³

* Air supply must be dry enough to avoid ice formation at temperatures below +2°C

Material Specification

Body:	Aluminium
Sight glass:	Polypropylene
Filter cover:	ABS
Seals:	Nitrile NBR
Drains:	Manual / Semi-auto: Acetal Automatic: PA / Brass connection
Coalescing element:	Borosilicate & Nano fibres
Top & bottom end cap:	Aluminium
Support cylinders:	Grade 430 stainless steel
Support media:	Polypropylene
Ensapulate:	Epoxy resin / Hardener

Dimensions (mm)

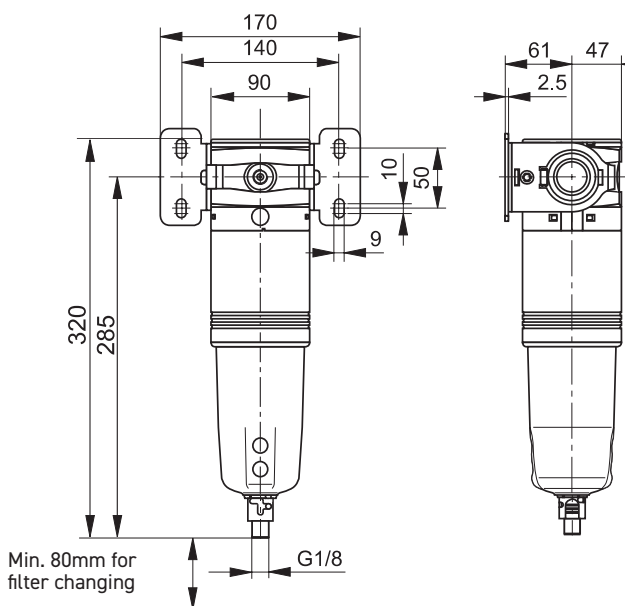

Flow characteristics

(1") 1µm Dust Filter Saturated

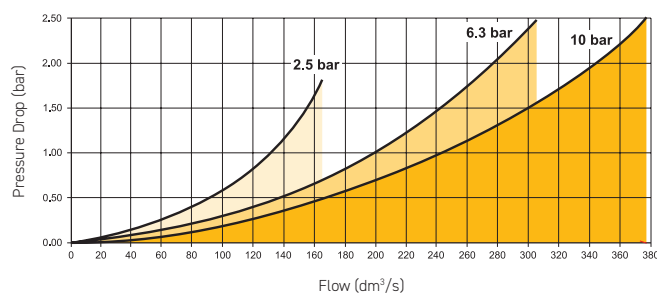

Service kits

Description	Order code
1 micron coalescing element kit	P3YKA00ES9
Bowl kit with combined manual/semi auto drain	P3YKA00BSC
Bowl kit with auto drain	P3YKA00BSA

Coalescing Filters



- Extended high efficiency filter element provides greater filtration surface area.
- Integral 3/4 or 1" ports (BSPP & NPT)
- Removes liquid aerosols and sub micron particles
- Oil free air for critical applications, such as air gauging, pneumatic instrumentation and control

Note: To optimise the life of the coalescing element, it is advisable to install a P3YFA pre-filter with a 5 micron element upstream of the coalescing filter.

Options:

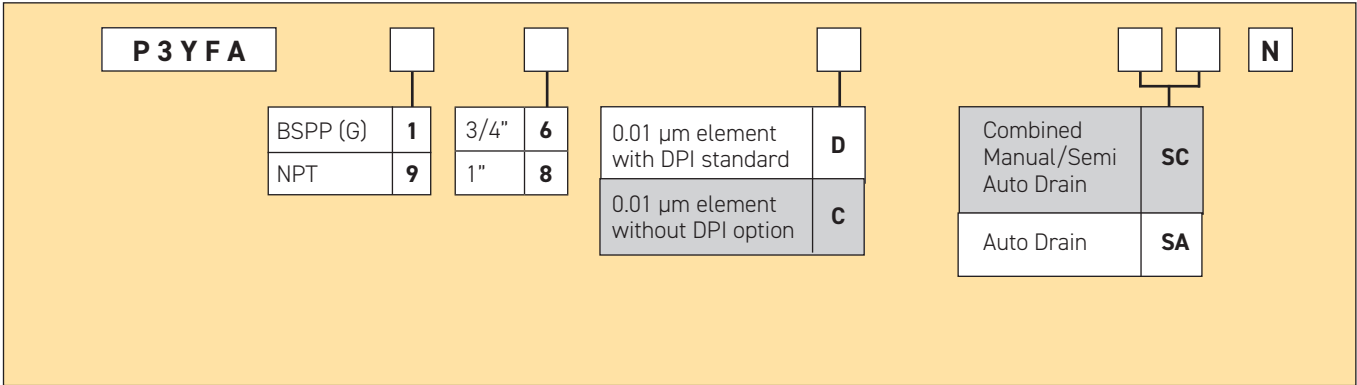

Port size	Description	Order Code	Flow dm ³ /s *	Max bar	Min temp °C	Max temp °C	Bowl capacity cm ³	Height mm	Width mm	Depth mm	Weight kg
3/4	Coalescing Filter 0.01µm, Combined manual/semi auto drain	P3YFA16DSCN	177	17.5	-10	60	130	340	90	94	1.6
3/4	Coalescing Filter 0.01µm, auto drain	P3YFA16DSAN	177	17.5	-10	60	130	340	90	94	1.6
1"	Coalescing Filter 0.01µm, Combined manual/semi auto drain	P3YFA18DSCN	145	17.5	-10	60	130	340	90	94	1.6
1"	Coalescing Filter 0.01µm, auto drain	P3YFA18DSAN	145	17.5	-10	60	130	340	90	94	1.6

* flow with 6,3 bar inlet pressure and 0,2 pressure drop

Technical Information

Fluid:	Compressed air
Maximum inlet pressure*:	17.5 bar
Temperature range*:	-10°C to +60°C
Media specifications:	
Coalescing efficiency	(0.3 to 0.6 micron particles): 99.97%
Max. oil carryover (PPM w/w):	0.008 mg/m ³
Typical flow element @ 6,3 bar inlet pressure and 0.2 bar pressure drop:	Dry element 0.01µm @ 59dm ³ /s
Manual/Semi-auto drain:	Bowl pressure to close drain 0.8 bar G1/8" thread
Auto drain:	
bowl pressure to close drain	0.8 bar
Operating range manual override facility (depress pin)	0.8 to 17.5 bar Ø 10mm brass connection
Bowl sump capacity:	130 cm ³

* Air supply must be dry enough to avoid ice formation at temperatures below +2°C

Material Specification

Body:	Aluminium
Sight glass:	Polypropylene
Filter cover:	ABS
Coalescing element:	Borosilicate & Nano fibres
Top & bottom end cap:	Aluminium
Support cylinders:	Grade 430 stainless steel
Support media:	Polypropylene
Anti re-entrainment barrier:	Polyester
Ensapulate:	Epoxy resin / Hardener
Seals:	Nitrile NBR
Drains:	Manual / Semi-auto: Acetal Automatic: PA / Brass connection

Differential pressure indicator materials:

Body:	Acetal
Internal parts:	Acetal
Spring:	Stainless steel
Seals:	Nitrile NBR
Support plate:	ABS
Screws:	Steel / zinc plated

Dimensions (mm)

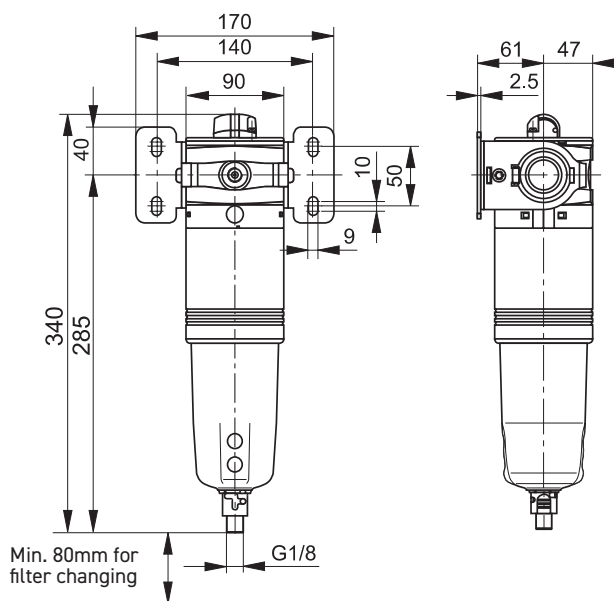

Service kits

Description	Order code
0.01 micron coalescing element kit	P3YKA00ESC
Bowl kit with combined manual/semi auto drain	P3YKA00BSC
Bowl kit with auto drain	P3YKA00BSA
Differential pressure indicator kit	P3YKA00RQ

Flow characteristics

(3/4") 0.01µm Coalescing Filter Saturated

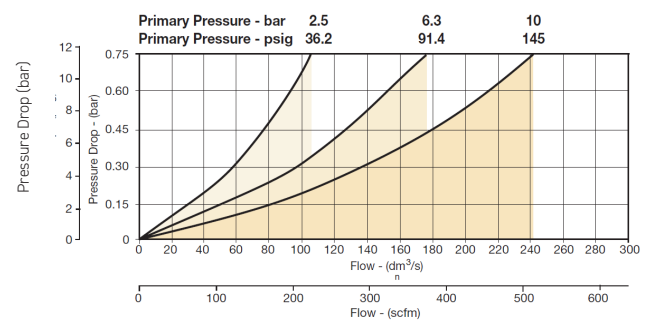

(1") 0.01µm Coalescing Filter Saturated

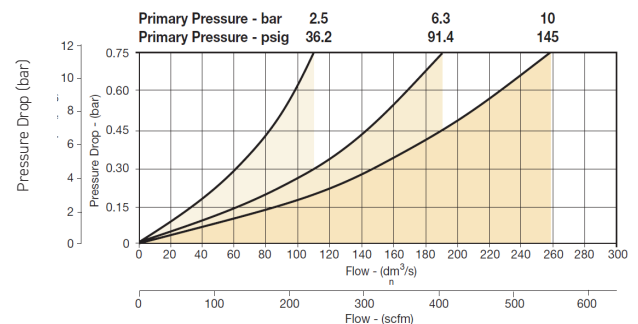

Adsorber Filter



- Integral 3/4 or 1" ports (BSPP & NPT)
- Adsorber activated carbon element removes oil vapours and most hydrocarbons

Note: To optimise the life of the adsorber element, it is advisable to install a P3Y coalescing 0.01 µm filter upstream of the adsorber filter.

Options:

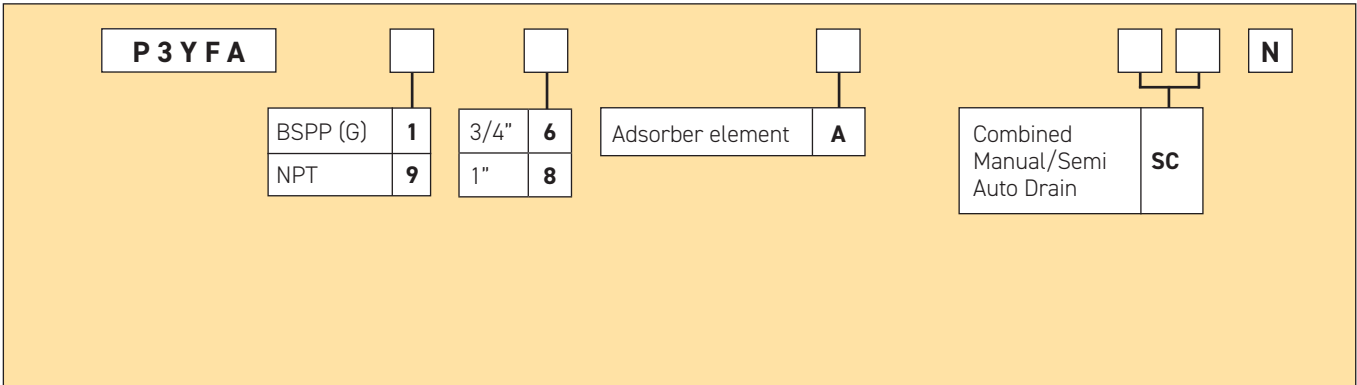

Port size	Description	Order Code	Flow dm ³ /s *	Max bar	Min temp °C	Max temp °C	Bowl capacity cm ³	Height mm	Width mm	Depth mm	Weight kg
3/4	Adsorber Filter, Combined Manual/Semi Auto drain	P3YFA16ASCN	177	17.5	-10	60	130	340	90	94	1.5
1"	Adsorber Filter, Combined Manual/Semi Auto drain	P3YFA18ASCN	145	17.5	-10	60	130	340	90	94	1.5

* flow with 6,3 bar inlet pressure and 0,2 pressure drop

Technical Information

Fluid:	Compressed air	
Maximum inlet pressure*:	17.5 bar	
Temperature range*:	-10°C to +60°C	
Media specifications:		
Max. oil carryover (PPM w/w):	0.008 mg/m ³	
Typical flow at 6,3 bar inlet pressure and 0.2 bar pressure drop:	1" Adsorber	50 dm ³ /s
Manual drain / Semi-auto drain:	G1/8" thread	
Bowl sump capacity:	130 cm ³	

* Air supply must be dry enough to avoid ice formation at temperatures below +2°C

Material Specification

Body:	Aluminium
Sight glass:	Polypropylene
Filter cover:	ABS
Adsorber element:	Activated carbon
Top & bottom endcap:	Glass filled nylon
Seals:	Nitrile NBR
Bayonet support:	Nylon
Drain: Manual / Semi-auto:	Acetal

Dimensions (mm)

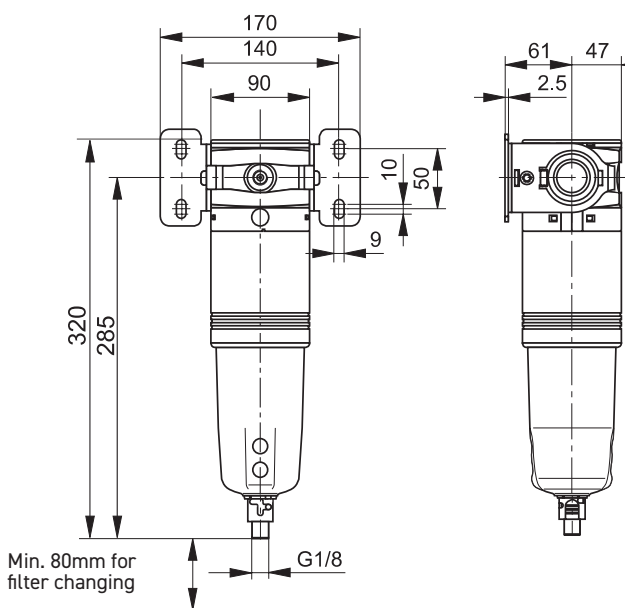

Service kits

Description	Order code
Adsorber element kit	P3YKA00ESA
Bowl kit with manual / semi-auto drain	P3YKA00BSC

Flow characteristics

(3/4") Adsorber Filter

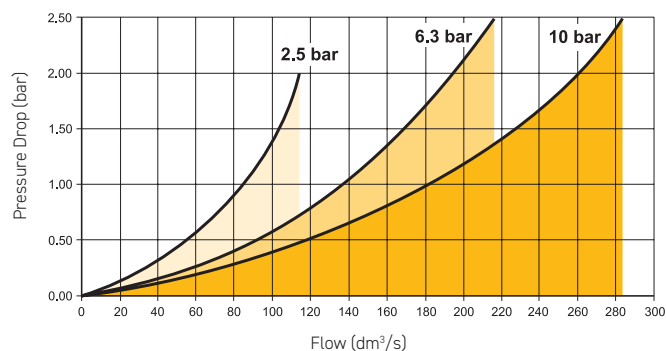

(1") Adsorber Filter

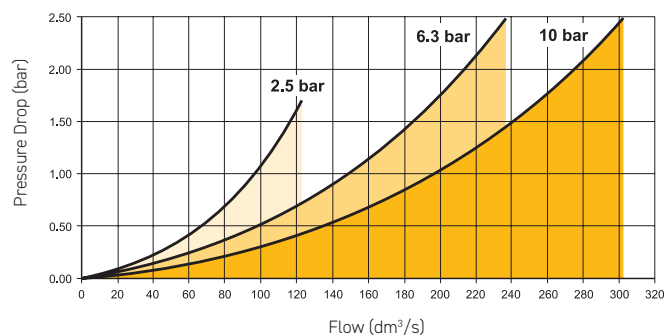

Regulator



Symbols

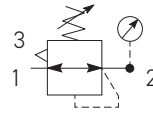

Self relieving regulator with gauge

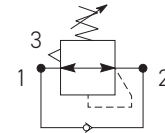

Reverse flow relieving regulator

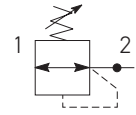

Non relieving regulator

- Integral 3/4 or 1" ports (BSPP & NPT)
- Robust but lightweight aluminium construction
- Secondary pressure ranges 12 & 16 bar
- Rolling diaphragm for extended life
- Secondary aspiration plus rolling diaphragm provides quick response and accurate pressure regulation.
- Optional tamperproof regulator padlock
- Relieving & Non-relieving types
- Reverse flow / relieving option
- Low temperature -40°C

Options:

P 3 Y R A								N	
BSPP (G)	1	3/4"	6	Relieving	B	Standard	N	0 - 12 bar No Gauge	E
NPT	9	1"	8	Reverse flow / Relieving	R	Lockable type	A	0 - 16 bar No Gauge	H

Port size	Description	Order Code	Flow dm ³ /s *	Max bar	Min temp °C	Max temp °C	Height mm	Width mm	Depth mm	Weight kg
3/4	12 bar relieving	P3YRA16BNEN	179	17.5	-40	60	182	90	94	1.08
1"	12 bar relieving	P3YRA18BNEN	260	17.5	-40	60	182	90	94	1.08
3/4	12 bar relieving, lockable	P3YRA16BAEN	179	17.5	-40	60	182	90	94	1.08
1"	12 bar relieving, lockable	P3YRA18BAEN	260	17.5	-40	60	182	90	94	1.08

* Flow with 10 bar inlet pressure, 6,3 bar set pressure and 1 bar pressure drop.

Lockable regulators will require key lock kit (see Accessories).

Technical Information

Fluid:	Compressed air
Maximum inlet pressure*:	17.5 bar
Temperature range*:	-40°C to +60°C
Typical flow with 10 bar inlet pressure, 6.3 bar set pressure and 1 bar pressure drop:	1" size 321 dm ³ /s
Gauge port (x 2):	1/4"

* Air supply must be dry enough to avoid ice formation at temperatures below +2°C

Material Specification

Body:	Aluminium
Bonnet:	Glass filled polyamide
Regulator cover:	ABS
Control Knob:	Glass filled polyamide
Valve:	Brass / NBR
Seals:	Nitrile NBR
Screws:	Steel / zinc plated

Dimensions (mm)

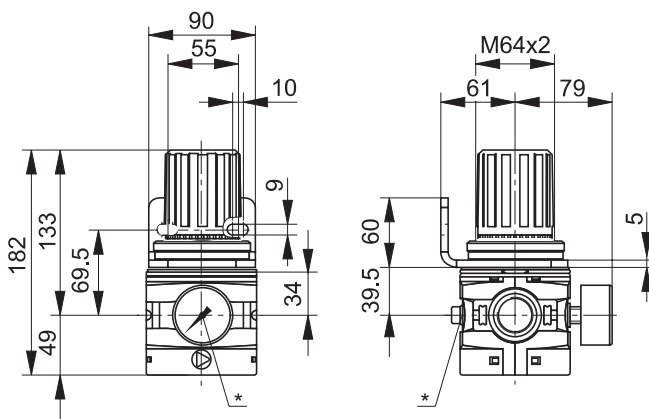

* 1/4" gauge port

Service kits

Description	Order code
Angle bracket + metal lock ring	P3YKA00MS
Panel mounting nut	P3YKA00MM
Key lock	P3XKA00AS
Diaphragm kit (relieving type)	P3YKA00RR
Diaphragm kit (non-relieving type)	P3YKA00RN
Pressure gauge 0 to 16 bar 1/4"	KG8013-00

Flow characteristics

Regulation characteristics: (3/4")

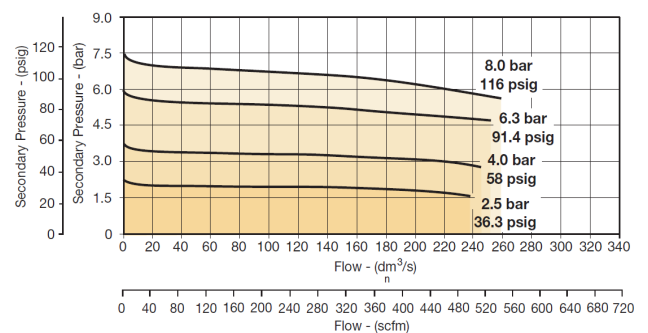

Regulation characteristics: (1")

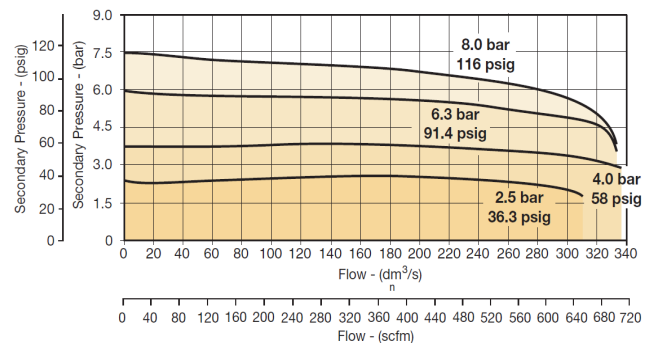

Filter-Regulator



Symbols

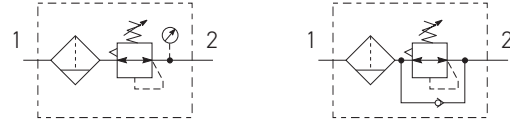

- Integral 3/4 or 1" ports (BSPP or NPT)
- High efficiency element as standard
- Excellent water removal efficiency
- Robust but lightweight aluminium construction
- Secondary pressure ranges 12 and 16 bar
- Rolling diaphragm for extended life
- Secondary aspiration plus balanced poppet provides quick response and accurate pressure regulation.
- Reverse flow / relieving option
- Low temperature -40°C with combined manual/semi-auto drain as standard

Options:

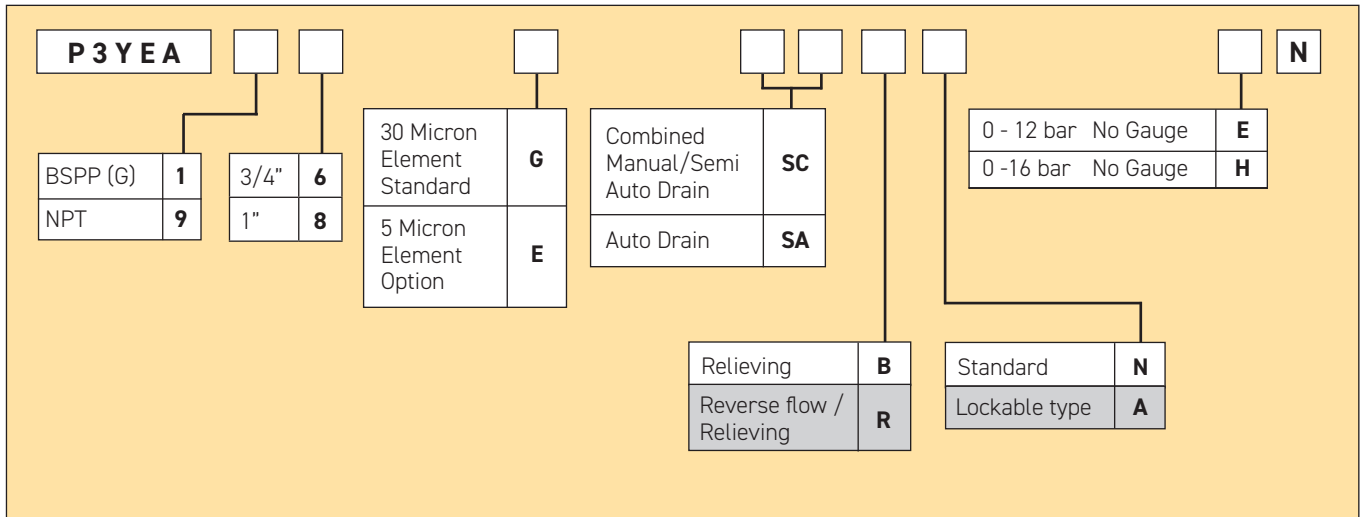

Port size	Description	Order Code	Flow dm ³ /s *	Max bar	Min temp °C	Max temp °C	Bowl capacity cm ³	Height mm	Width mm	Depth mm	Weight kg
3/4	12 bar, relieving, Combined manual/semi auto drain 30µ	P3YEA16GSCBNEN	190	17.5	-40	60	130	345	90	94	1.5
3/4	12 bar relieving, auto drain 30µ	P3YEA16GSABNEN	190	17.5	-10	60	130	345	90	94	1.5
1"	12 bar, relieving, Combined manual/semi auto drain 30µ	P3YEA18GSCBNEN	237	17.5	-40	60	130	345	90	94	1.5
1"	12 bar relieving, auto drain 30µ	P3YEA18GSABNEN	237	17.5	-10	60	130	345	90	94	1.5

* flow with 10 bar inlet pressure, 6,3 bar set pressure and 1 bar pressure drop.

Technical Information

Fluid:	Compressed air
Maximum inlet pressure*:	17.5 bar
Temperature range*:	
Auto drain :	-10°C to +60°C
Combined drain :	-40°C to +60°C
Particle removal:	5 micron and 30 micron
Air quality:	Within ISO 8573-1 : 1991 Class 3 and 5 (particulates) Within ISO 8573-1 : 2001 Class 6 and 7 (particulates)
Typical flow with 10 bar inlet pressure 6,3 bar set pressure and 1 bar pressure drop 1" size	237 dm ³ /s
Manual/Semi-auto drain:	0,8 bar bowl pressure to close drain G1/8" thread
Auto drain:	
bowl pressure to close drain	0.8 bar
Operating range	0.8 to 17.5 bar
manual override facility (depress pin)	Ø 10mm brass connection
Bowl sump capacity:	130 cm ³
Gauge ports (x 2):	1/4"

* Air supply must be dry enough to avoid ice formation at temperatures below +2°C

Dimensions (mm)

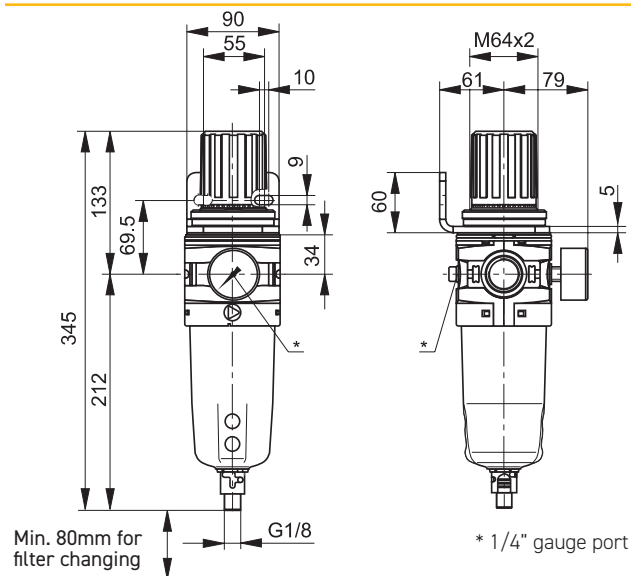

Service kits

Description	Order code
5 micron element kit	P3YKA00ESE
30 micron element kit	P3YKA00ESG
Bowl kit with combined manual/semi auto drain	P3YKA00BSC
Bowl kit with auto drain	P3YKA00BSA
Key Lock Kit	P3XKA00AS
Diaphragm kit (relieving type)	P3YKA00RR
Diaphragm kit (non-relieving type)	P3YKA00RN
Angle bracket + metal lock ring	P3YKA00MS
Panel mount nut	P3YKA00MM
Pressure gauge 0 to 16 bar 1/4"	KG8013-00

Material Specification

Body:	Aluminium
Sight glass:	Polypropylene
Body cover:	ABS
Element:	Sintered polypropylene
Seals:	Nitrile NBR
Drains:	Manual / Semi-auto: Acetal Automatic: PA / Brass connection
Bonnet:	Glass filled polyamide
Control knob:	Glass filled polyamide
Valve:	Brass / NBR
Screws:	Steel/ zinc plated

Flow characteristics

(3/4") 30 Micron Filter/Regulator

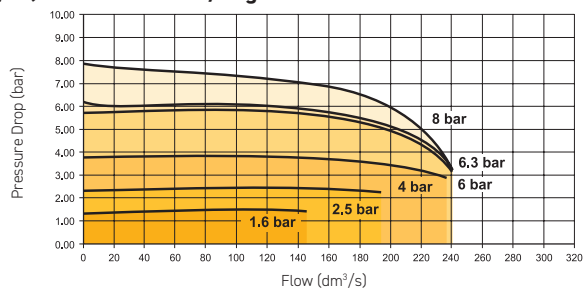

(1") 30 Micron Filter/Regulator

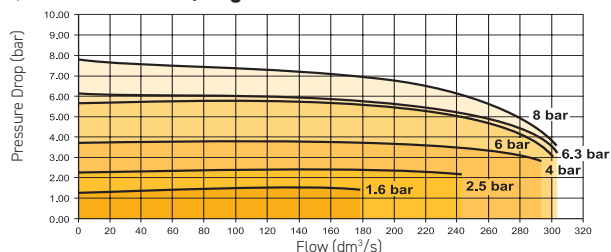

(3/4") 5 Micron Filter/Regulator

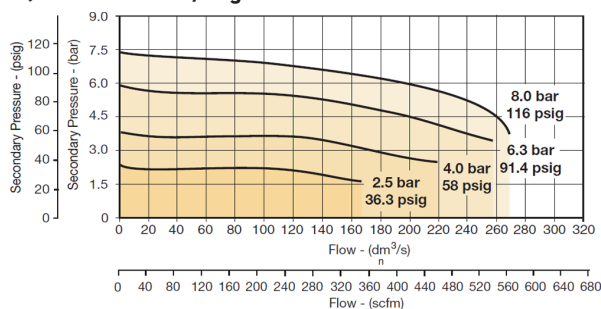

(1") 5 Micron Filter/Regulator

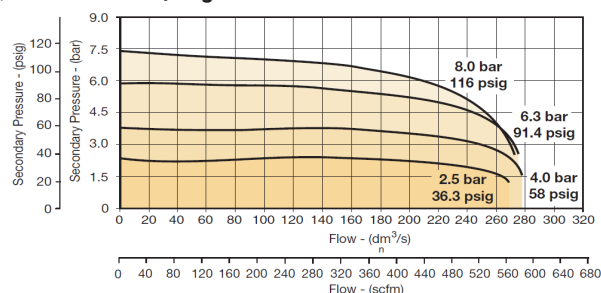

Lubricator



Symbols

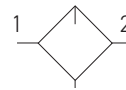

Lubricator with drain

- Integral 3/4 or 1" ports (BSPP & NPT)
- Robust but lightweight aluminium construction
- Proportional oil delivery over a wide range of air flows.
- Possible to fill under system pressure eliminating down time
- Large oil reservoir

Options:

P 3 Y L A					L S N N
BSPP (G)	1	3/4"	6		
NPT	9	1"	8		

Port size	Description	Order Code	Flow dm ³ /s *	Max bar	Min temp °C	Max temp °C	Bowl capacity cm ³	Height mm	Width mm	Depth mm	Weight kg
3/4	Oil mist, fill under pressure	P3YLA16LSNN	148	17.5	-10	60	500	247	90	94	0.8
1"	Oil mist, fill under pressure	P3YLA18LSNN	184	17.5	-10	60	500	247	90	94	0.8

* flow with 6,3 bar inlet pressure and 0,5 pressure drop.

Technical Information

Fluid:	Compressed air
Maximum inlet pressure*:	17.5 bar
Temperature range*:	-10°C to +60°C

* Air supply must be dry enough to avoid ice formation at temperatures below +2° C
 Low flow start point (lubrication pick-up): at 6.3bar inlet pressure 0.5 dm³/s
 Typical flow with 6.3bar inlet pressure and 0.7 bar pressure drop: 184 dm³/s

Material Specification

Body:	Aluminium
Bowl sight glass:	Polypropylene
Sight dome:	Polyamide
Lubricator cover:	ABS
Bayonet support:	Nylon
Seals:	Nitrile NBR

Dimensions (mm)

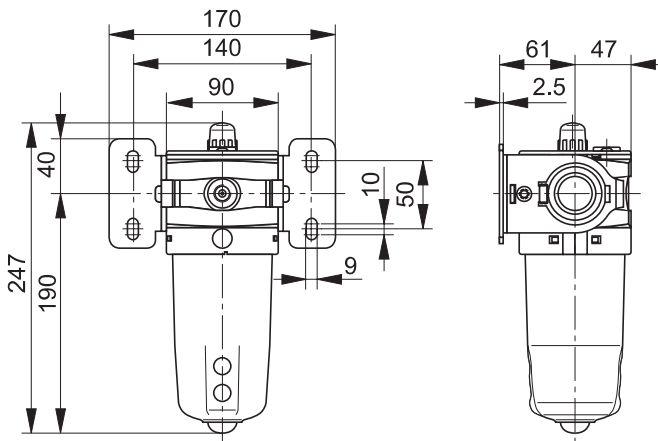

Flow characteristics

(3/4") Lubricator

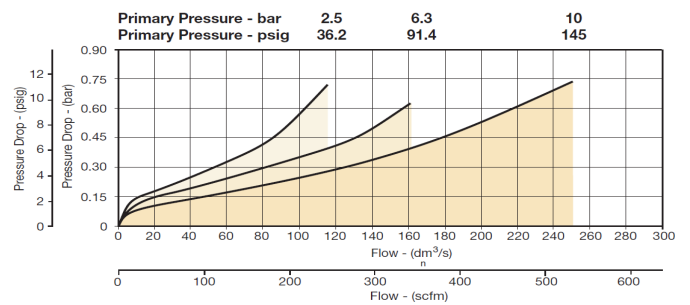

(1") Lubricator

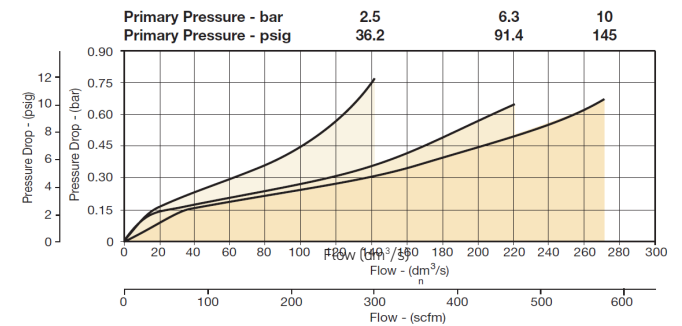

Service kits

Description	Order code
Bowl kit	P3YKA00BSN
Refill plug	P3YKA00PL
Lubricator Oil	P3YKA00PPBB

Proportional Pressure Regulator



- Integral 3/4 or 1" ports (BSPP & NPT)
- Accurate output pressure
- Very fast response times
- Robust but lightweight design.

Options:

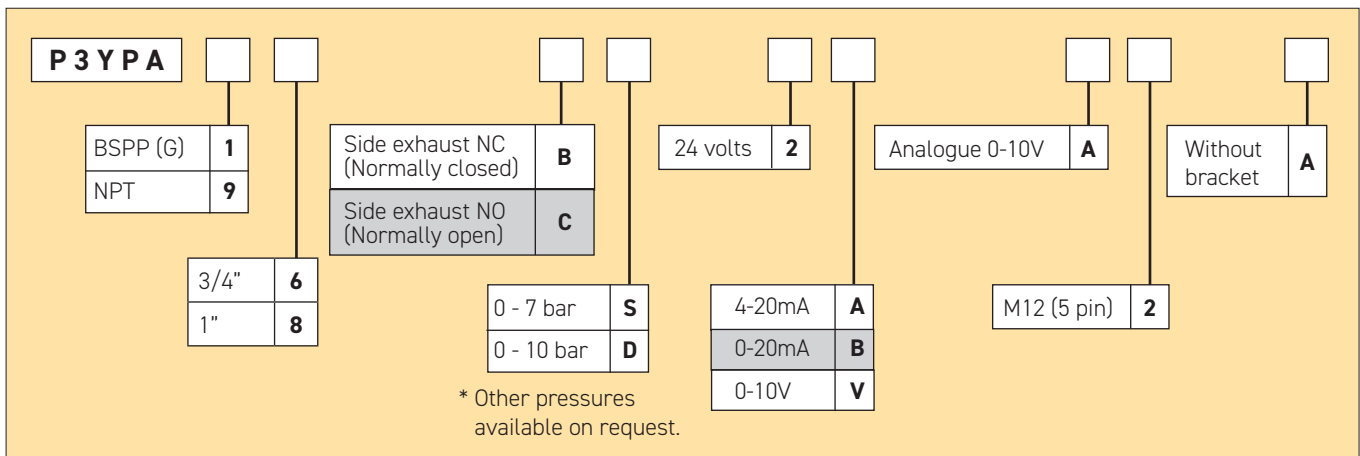

Popular options:

Port size	Description	Order Code	Control signal	Output signal	Output pressure	Weight kg
3/4	Normally closed	P3YPA16BD2VA2A	0 - 10 V	0 - 10 V	0 - 10 bar	1.2
1"	Normally closed	P3YPA18BD2VA2A	0 - 10 V	0 - 10 V	0 - 10 bar	1.2

Technical Information

Operating pressure range	P ¹ min	1 bar
Inlet pressure ¹⁾	P ¹ max	16 bar
Operating pressure range	P ² min	0.2 bar
Outlet pressure	P ² max	10 bar
Operating Temperature	0°C to +50°C	
Maximum Flow	33 dm ³ /s	
Hysteresis	P ² max	< 1%
Repeatability	P ² max	< 0.5%
Sensitivity	P ² max	< 0.5%
Linearity	P ² max	< 1%
Nominal voltage	U _n V DC 24V = ±10%	
Residual ripple	10%	
Power consumption	I _{Bmax}	0.15 A
Set value input	U _w	V 0 - 10
	I	mA 0 - 20
		mA 4 - 20
Input resistance	R _E	243 K
Actual valve output	U _x	0 - 10 $\sqrt{\Omega}$
Output current	I _{Amax}	10 mA
Degree of protection	IP65 to DIN 40050, EN 60529	

1) p₁ > p₂ + 10% p₂

2) at p₁ - 10 bar to p₂ - 6.3 bar

Dimensions (mm)

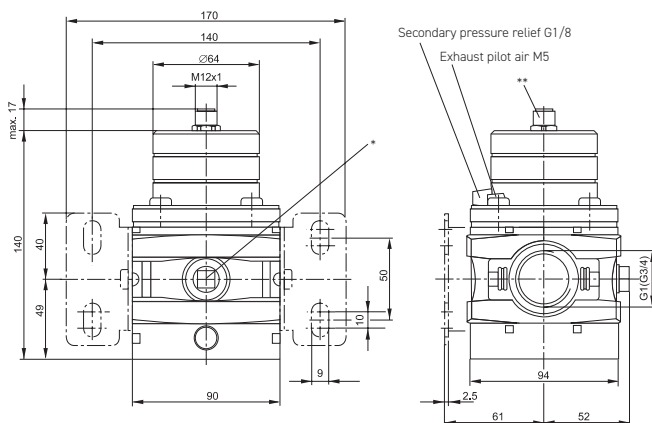

* Two opposite gauge ports G1/4, plug screw mounted

** Connection for 5-pin plug M12 x 1

Material Specification

Housing:	Aluminium
Pilot valve booster:	Brass / NBR composite aluminium
Standard seals:	NBR
Body cover screws:	Steel / zinc plated

Connection diagram

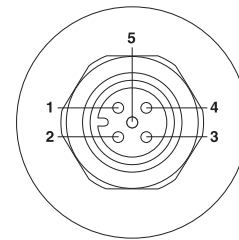

Connector M12 x 1

Pin 1:
Power supply
Plus +24 V DC ± 10%
0.15 A
Residual ripple 10%

Pin 2:
Power supply 0 V
Reference and mass capacity
for set value and actual value

Pin 3:
Set value input
0 - 10 V

Pin 4:
0 V set signal
(connected on board
with pin 2 as standard)

Pin 5:
Analogue actual value output
0 - 10 V
Tolerance ± 0.15 V

Flow characteristics

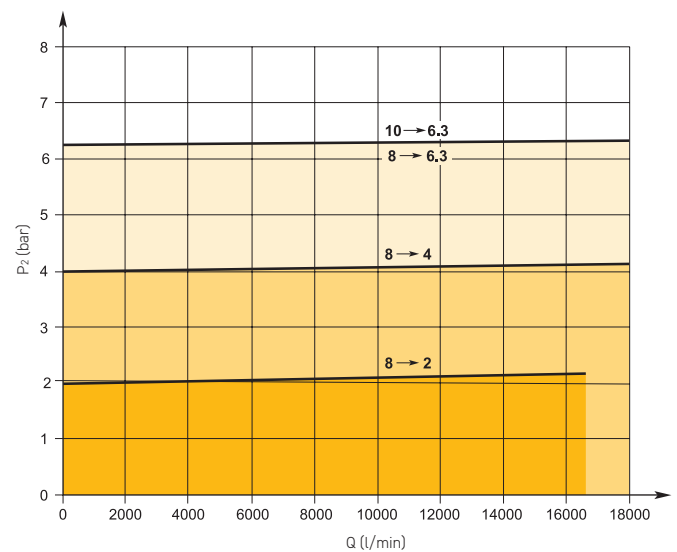

Combined Soft Start Dump Valve and Remote Operated Dump Valve



Symbols

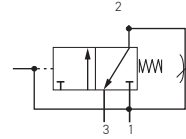

- Modular design with 3/4 & 1" integral ports (BSPP or NPT)
- Provides for the safe introduction of pressure
- Automatically dumps downstream pressure on the loss of pilot signal
- Adjustable slow start
- Solenoid or air pilot options
- High flow & exhaust capability

P3Y Series Combined Soft Start/Dump Valves, provide for the safe introduction of pressure to machines or systems. Soft Start/Dump Valves when set, allow the pressure to gradually build to the set point before fully opening to deliver full flow at line pressure.

The controlled introduction of pressure can be an important safety factor and prevent damage to tooling when air pressure is introduced at machine or system start up.

Options:

P 3 Y T A	BSPP (G)	1	External air pilot	P	N	None (operator is fitted to valve)	0	Solenoid type only	
	NPT	9		Solenoid pilot			S	30mm CNOMO coil (Form connection)	A
	3/4"	6	30mm operator	C		22mm coil (Form connection)	B	24V DC	2CN
	1"	8	External air pilot	P					

Combined soft start dump valve

Port size	Description	Order Code	Flow dm ³ /s	Max bar	Min temp °C	Max temp °C	Height mm	Width mm	Depth mm	Weight kg
3/4	Solenoid operated (not included)	P3YTA16SCN0000	175	16	-10	60	130	90	104	1.5
3/4	24VDC 22mm coil	P3YTA16SCNB2CN	175	10	-10	60	191	90	104	1.6
3/4	Air pilot operated	P3YTA16PPN	175	17.5	-10	60	145	90	104	1.4
3/4	24vDC 30mm coil	P3YTA16SCNA2CN	175	16	-10	60	130	90	104	1.6
1"	Solenoid operated (not included)	P3YTA18SCN0000	200	16	-10	60	130	90	104	1.5
1"	24VDC 22mm coil	P3YTA18SCNB2CN	200	10	-10	60	191	90	104	1.6
1"	Air pilot operated	P3YTA18PPN	200	17.5	-10	60	130	90	104	1.4
1"	24vDC 30mm coil	P3YTA18SCNA2CN	175	16	-10	60	130	90	104	1.6

Technical Information

Fluid:	Compressed air	
Max. pressure solenoid operated 22mm coil:	10 bar	
Max. pressure solenoid operated 30mm coil:	16 bar	
Minimum operating pressure:	2 bar	
Temperature range* Solenoid operated:	-10 ^o to + 60 ^o C	
Temperature range* Air Pilot operated:	-10 ^o to + 60 ^o C	
Air Pilot port:	1/8"	
Exhaust port:	1" / 3/4"NPT	
Gauge port:	1/4"	
Typical flow with 6.3bar inlet pressure and 1 bar pressure drop:	3/4"	175 dm ³ /s
	1"	200 dm ³ /s

* Air supply must be dry enough to avoid ice formation at temperatures below +2°C
Snap pressure: Full flow when downstream pressure reaches 50% of the inlet pressure

Dimensions (mm)

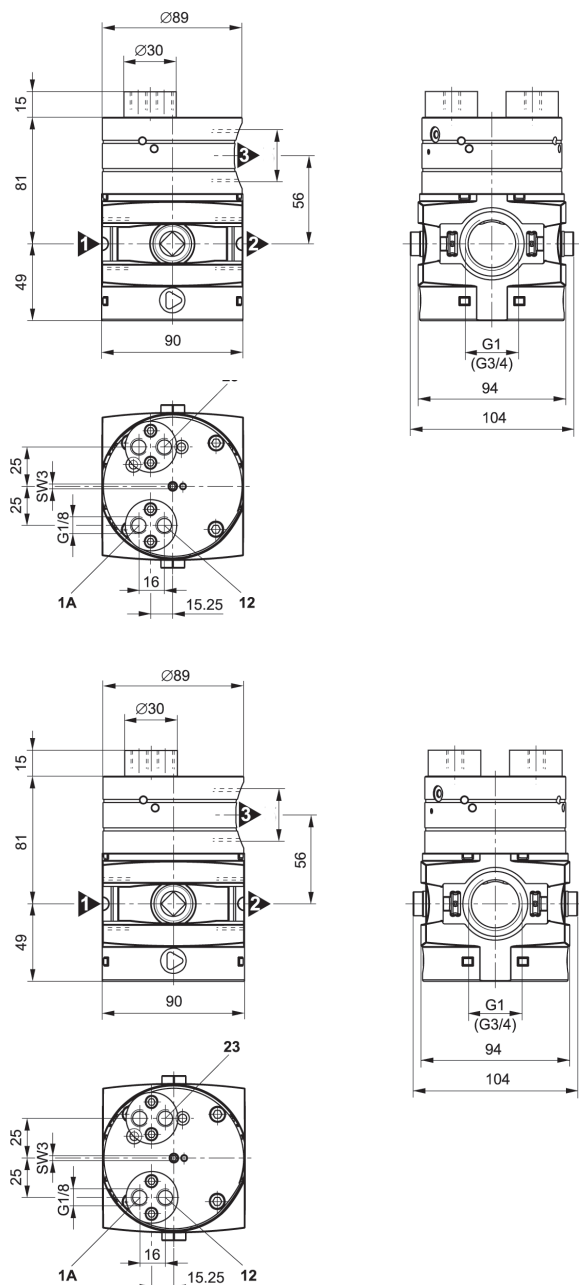

Material Specification

Body:	Aluminium
Body cover:	ABS
Valve:	Brass / NBR composite
Pilot valve booster:	Aluminium
Seals:	Nitrile NBR

Note: For solenoid coil and cable plug options see page 30.

Flow characteristics

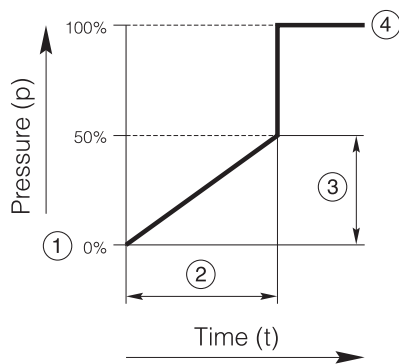

- ① Start signal
- ② Switching time delay
- ③ Gradual pressure build up
- ④ Operating pressure p² (=p¹)

Combined start/stop function

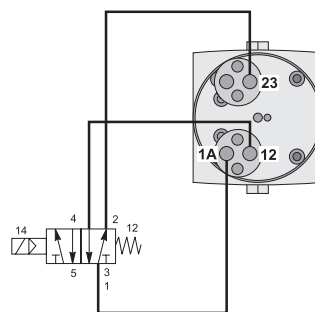

Combined start/stop function with acknowledgement

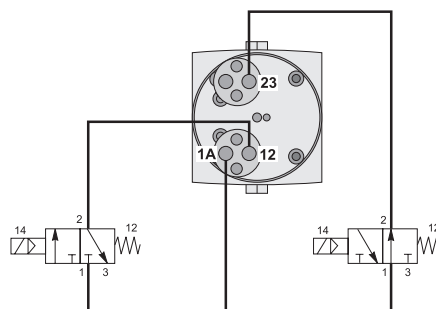

Soft Start Valve



Symbols

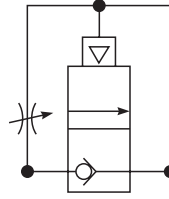

- Integral 3/4" or 1" ports
- Smooth start-up of pneumatic system
- Air pilot operation
- Adjustable slow start
- High flow

Options:

P3YSA			Y	O	N
BSPP (G)	1	3/4"	6		
NPT	9	1"	8		

Soft start valve

Port size	Description	Order Code	Flow dm ³ /s	Max bar	Min temp °C	Max temp °C	Height mm	Width mm	Depth mm	Weight kg
3/4"	Soft start valve	P3YSA16Y0N	153	17.5	-10	60	85	90	97	0.8
1"	Soft start valve	P3YSA18Y0N	142	17.5	-10	60	85	90	97	0.8

Technical Information

Fluid:	Compressed air
Maximum pressure Air Pilot operated:	17.5 bar
Minimum operating pressure:	2 bar
Temperature range* Solenoid operated:	-10 ⁰ to + 60 ⁰ C
Temperature range* Air Pilot operated:	-10 ⁰ to + 60 ⁰ C
Typical flow with 6.3bar inlet pressure and 1 bar pressure drop:	180 dm ³ /s

* Air supply must be dry enough to avoid ice formation at temperatures below +2°C
 Snap pressure: Full flow when downstream pressure reaches 50% of the inlet pressure

Material Specification

Body:	Aluminium
Body cover:	ABS
Valve:	Brass / NBR composite
Pilot valve booster:	Aluminium
Seals:	Nitrile NBR

Dimensions (mm)

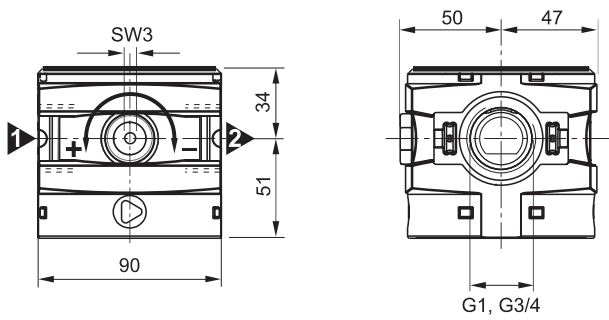

Flow characteristics

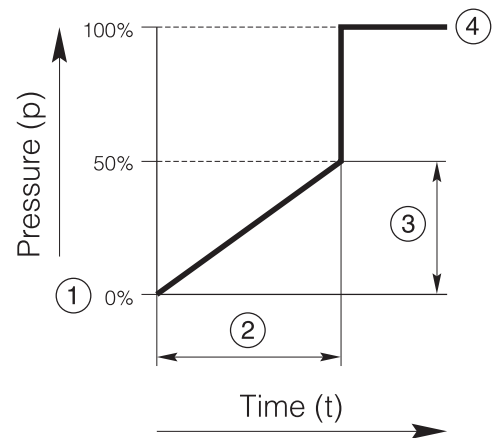

- ① Start signal
- ② Switching time delay
- ③ Gradual pressure build up
- ④ Operating pressure $p^2 (=p^1)$

Pilot Operated Regulator

Symbol

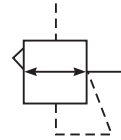
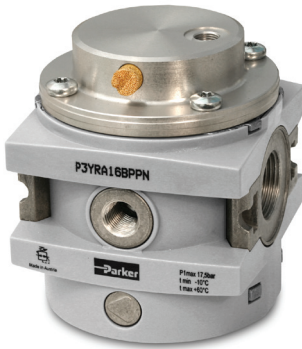

- Integral 3/4 or 1" ports (BSPP & NPT)
- Pilot controlled regulators can be mounted 'out of reach' with pilot regulator installed in a convenient location
- Constant pilot bleed control for accurate pressure control
- Balanced poppet provides quick response
- High flow

Options:

P 3 Y	R A			B P P N	
		BSPP (G)	1	3/4"	6
		NPT	9	1"	8

Pilot Operated Regulator

Port size	Description	Order Code	Flow dm ³ /s	Max bar	Min temp °C	Max temp °C	Height mm	Width mm	Depth mm	Weight kg
3/4	Pilot operated regulator	P3YRA16BPPN	260	17.5	-10	60	105.5	90	90	1.2
1"	Pilot operated regulator	P3YRA18BPPN	260	17.5	-10	60	105.5	90	90	1.2

* Flow with 10 bar inlet pressure, 6.3 bar set pressure and 1 bar pressure drop.

Technical Information

Flow Capacity:	3/4	260 dm ³ /s
	1"	260 dm ³ /s
Operating Temperature:	-10°C to +60°C	
Maximum Supply Pressure:	17.5 bar	
Weight (g):	3/4	1.2 kg
	1"	1.2 kg

Material specification:

Body:	Aluminium
Body cover:	ABS
Seals:	Nitrile NBR
Screws:	Zinc plated steel
Valve:	Brass / NBR composite
Pilot valve booster:	Aluminium

Dimensions (mm)

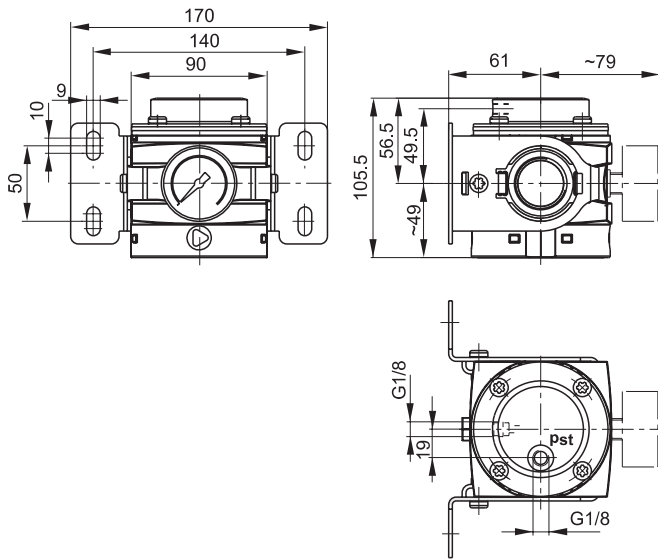

Flow characteristics

Pilot Operated Regulator

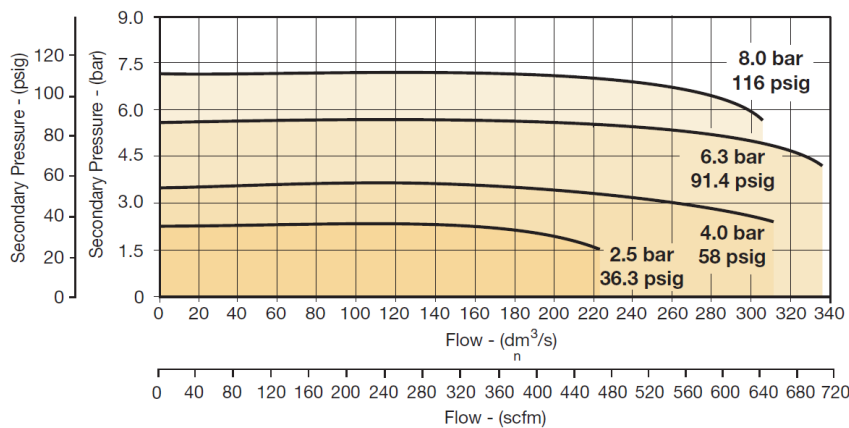

Modular Ball Valve

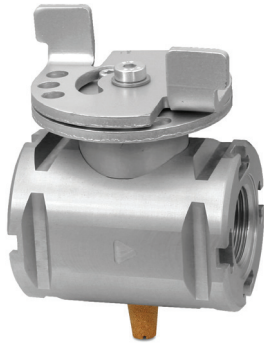

Symbols

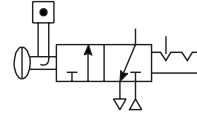

- Positive bubble tight shut-off.
- 90° turn handle to prevent unauthorised adjustment.
- Padlockable (up to 6 times).
- When the inlet pressure is turned off the downstream vents through the exhaust port.

P3Y Series Ball Valves provide shut off line pressure with a non-sticking 90° turn handle to prevent unauthorised adjustment. When the inlet pressure is turned off the downstream vents through the exhaust port.

Options:

P 3 Y	V A	□	□	L B N	
		BSPP (G)	1	3/4"	6
		NPT	9	1"	8

Technical Information

Flow Capacity:	3/4	333 dm ³ /s
	1"	333 dm ³ /s
Operating Temperature:	-10°C to +60°C	
Maximum Supply Pressure:	17.5 bar	
Weight (kg):	3/4	1.1
	1"	1.1

Material specification:

Body:	Aluminium
Valve ball:	Brass / Nickle plated
Handle:	Aluminium
Seals:	Nitrile NBR
Exhaust silencer:	Sintered bronze

Dimensions (mm)

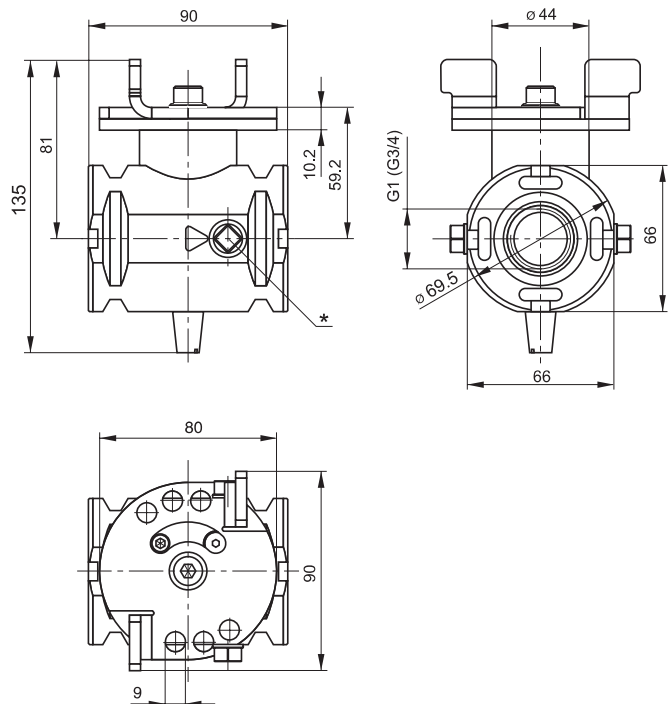

Modular Manifold

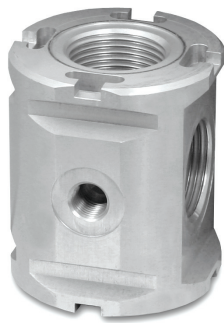

P3Y Series Manifolds, provide up to 4 extra outlet ports, they may be assembled at any position in a combination e.g. before the lubricator to provide oil free take off or at the end of a combination to provide extra outlet ports.

Inlet port	Top	Bottom	Front and Back
3/4"	1/8"	1"	1/4"
1"	1/8"	1"	1/4"

Material specification:

Body:	Aluminium
Weight (kg):	0.7

Thread type	Order code
BSPP	P3YMA1V0N
NPT	P3YMA9V0N

Dimensions (mm)

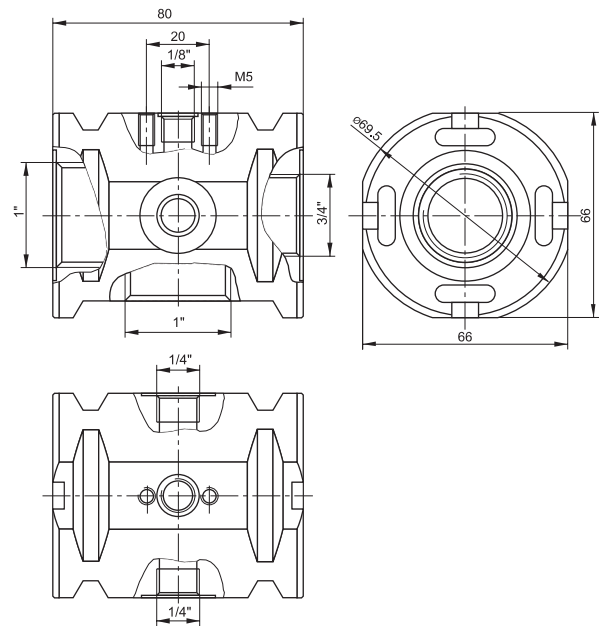

Thread type	Order code
BSPP	P3YMA16024N
NPT	P3YMA96024N

Inlet port	Top	Bottom	Front and Back
30mm	1/4"	1/2"	N/A

Material specification:

Body:	Aluminium
Weight (kg):	0.3

Dimensions (mm)

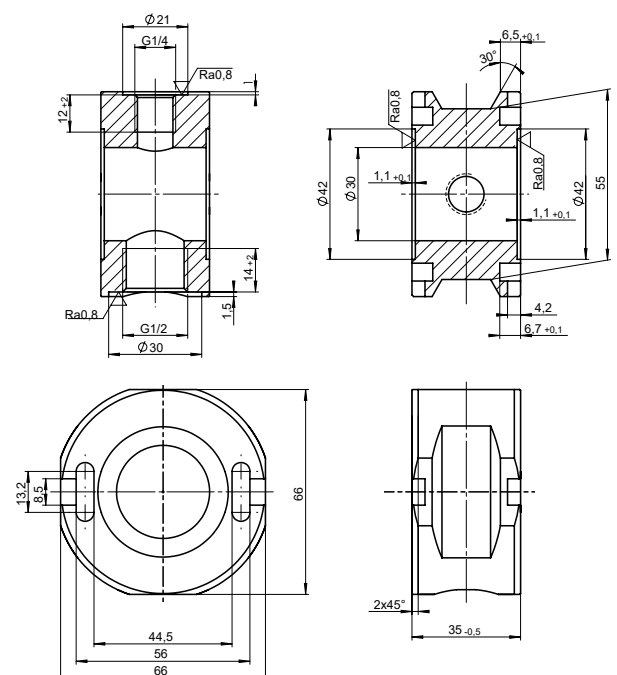

Optional Port Block Kits

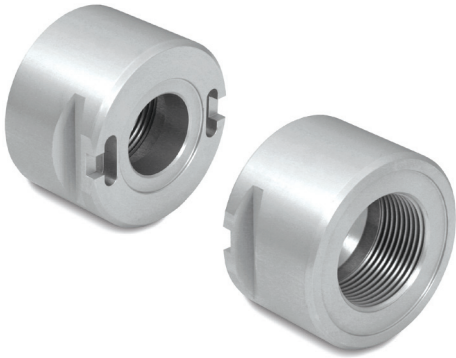

- To change port sizes Port Block Kits are available, they are attached to any unit utilising the connecting kit.
- Allows assemblies to be removed from a hard piped system.

Options:

P 3 Y K A				C P	
BSPP (G)	1	1 1/4"	A		
NPT	9	1 1/2"	B		

Material specification:

Body: Aluminium

Weight (kg): 0.65

Solenoid operator - CNOMO

Order key

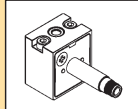
P	2	F	P	2	3	N	4	B	
Operator Type			Pressure / Temp			Manual / Override			
2 CNOMO 22 x 30 Plastic			N 10 bar / -10°C to +50°C			B Non locking - monostable - Flush - Brass			

Technical data - Solenoid operators, coil combinations

	NC Normal Operator with 30 x 30 standard coil	NC Normal Operator with 22 x 30 standard coil
Working pressure	0 to 10 bar	0 to 10 bar
Ambient temperature	-10 °C to 60 °C (1)	-10 °C to 60 °C (1)
Orifice	1.3/1.5mm	1.3/1.5mm
Flow Qn	0.84 dm ³ /s	0.84 dm ³ /s
Power (DC)	2.7W	4.8W
Power (AC)	4.9VA	8.5VA
Voltage tolerance	+/- 10%	+/- 10%
Duty cycle	100%	100%
Insulation class	F	F
Electric connection	Form A	Industrial B
Protection	IP65	IP65
Shock & Vibration	1g	1g
Approval	UL/CSA	
Working media	All neutral media such as compressed air and inert gases.	

(1) limited to 50°C if use with 100% duty cycle

Transients

Interrupting the current through the solenoid coil produces momentary voltage peaks which, under unfavourable conditions, can amount to several hundred times the rated operating voltage. Normally, these transients do not cause problems, but to achieve the maximum life of relays in the circuit (and particularly of transistors, thyristors and integrated circuits) it is desirable to provide protection by means of voltage-dependent resistors (varistors). All connectors/cable plugs EN175301-803 with LED's include this type of circuit protection.

Materials

Pilot Valve	
Body:	Polyamide
Armature tube:	Brass
Plunger & core:	Corrosion resistant Cr-Ni steel
Seals:	FKM (Viton™)
Screws:	Stainless steel

Coil

Encapsulation material:	Thermoplastic as standard Duroplast for M12 connection
-------------------------	---

Solenoid coils with Din A or Industrial B connection

Voltage	30mm x 30mm		Weight (Kg)	22mm x 30mm	
	Order code DIN A Standard			Order code Industrial B standard	Weight (Kg)
Direct current					
12V DC	P2FCA445	0.105	P2FCB445	0.093	
24V DC	P2FCA449	0.105	P2FCB449	0.093	
48V DC	P2FCA453*	0.105	P2FCB451	0.093	
Alternative current					
12V 50/60Hz	P2FCA440	0.105	P2FCB440	0.093	
24V 50/60Hz	P2FCA442	0.105	P2FCB442	0.093	
48V 50/60Hz	P2FCA469#	0.105			
110V 50Hz, 120V 60Hz	P2FCA453*	0.105	P2FCB453	0.093	
230V 50Hz, 230V 60Hz	P2FCA457	0.105	P2FCB457	0.093	

* P2FCA453 is compatible with 110 V AC and 48 V DC
P2FCA469 is 24 V DC 6.8W or 48 V 50Hz 9.9 VA

Solenoid coils with M12 connection

Voltage	Order code Form A		W (Kg)	Order code Form B	
	30 x 30			22 x 30	W (Kg)
Direct current					
24V DC	P2FC6419	0.065	P2FC7419	0.065	

Spare Solenoid Operators

Solenoid pilot operator CNOMO NC

Description	Order code	Weight (Kg)
	Non-lock manual override	
Standard duty	P2FP23N4B	0.065

Note. Sole-noid pilot operators are fitted to the Global range. Order the above part numbers for spares. The operators are supplied with mounting screws and interface 'O' rings. **Coils and connectors must be ordered separately.**

Spare Solenoid Nuts

Valves requiring captured exhaust should be fitted with plastic knurled nut



Order code	P2FNP
------------	--------------

Valves with vented exhaust are fitted with diffuser plastic nut

Order code	P2FND
------------	--------------



Solenoid Connectors / Cable Plugs EN175301-803

	Description	Order code	Order code
		22mm Form B Industrial	30mm Form A ISO4400
With standard screw 	Standard IP65 without flying lead	3EV10V10	3EV290V10
	With LED and protection 24V AC/DC	3EV10V20-24	3EV290V20-24
	With LED and protection 110V AC	3EV10V20-110	3EV290V20-110
	With LED and protection 230V AC	3EV10V20-230	3EV290V20-230
With cable 	24V AC/DC, 5m cable LED and protection IP65	3EV10V20-24L5	3EV290V20-24L5
	110V AC/DC, 5m cable LED and protection IP65	3EV10V20-110L5	3EV290V20-110L5
	230V AC, 5m cable LED and protection IP65	3EV10V20-230L5	3EV290V20-230L5

Solenoid Coil & Cable Plug Dimensions (mm)

P2F - 22 x 30mm - CNOMO

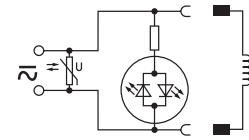
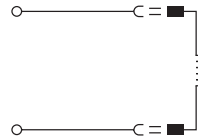
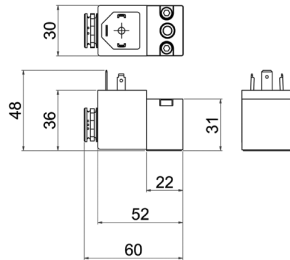
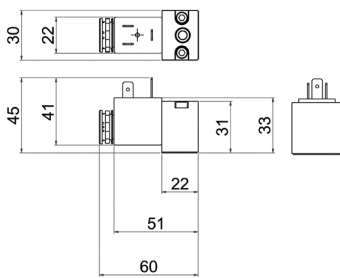

P8C-C
P8C-D
P8L-C2
P8L-C5
3EV10V10

P8C-D26C	P8L-C226C
P8C-D21E	P8L-C526C
P8C-C26C	P8L-CA26C
P8C-C21E	P8L-C221E
	P8L-C521E

Form B Cable plugs

3EV10V10

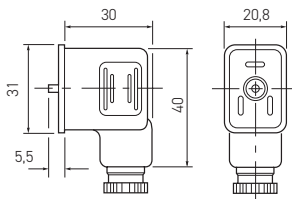

Form A Cable plugs

3EV290V10

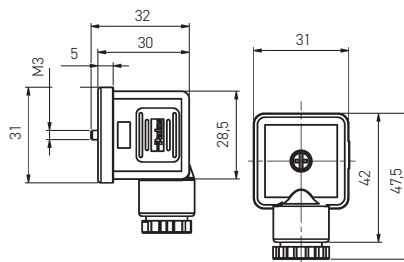

3EV10V20-24	3EV10V20-24L5
3EV10V20-110	3EV10V20-110L5
3EV10V20-230	3EV10V20-230L5

Accessories

Description	Connection	Weight	Order code (kg)		
Panel mounting nut (Aluminium)			0.70	P3YKA00MM	
Neck mounting bracket kit			3.75	P3YKA00MS	
Wall mounting brackets			0.2	P3YKA00CW	
P3Y connecting kit			0.05	P3YKA00CB	
Regulator & Filter/Regulator - Key Lock Kit			0.05	P3XKA00AS	
Pressure gauge	0 to 16 bar	1/4"	0.06	KG8013-00	
Lubricator Oil	VG32 - 1 litre		0.92	P3YKA00PPBB	
Connector O-ring kit	Qty: 5			P3YKA08CY	

Parker Worldwide

Europe, Middle East, Africa

AE – United Arab Emirates, Dubai

Tel: +971 4 8127100
parker.me@parker.com

AT – Austria, St. Florian

Tel: +43 (0)7224 66201
parker.austria@parker.com

AZ – Azerbaijan, Baku

Tel: +994 50 2233 458
parker.azerbaijan@parker.com

BE/NL/LU – Benelux,

Hendrik Ido Ambacht
Tel: +32 (0)0541 585 000
parker.nl@parker.com

BG – Bulgaria, Sofia

Tel: +359 2 980 1344
parker.bulgaria@parker.com

BY – Belarus, Minsk

Tel: +48 (0)22 573 24 00
parker.poland@parker.com

CH – Switzerland, Etoy

Tel: +41 (0)21 821 87 00
parker.switzerland@parker.com

CZ – Czech Republic, Klecany

Tel: +420 284 083 111
parker.czechrepublic@parker.com

DE – Germany, Kaarst

Tel: +49 (0)2131 4016 0
parker.germany@parker.com

DK – Denmark, Ballerup

Tel: +45 43 56 04 00
parker.denmark@parker.com

ES – Spain, Madrid

Tel: +34 902 330 001
parker.spain@parker.com

FI – Finland, Vantaa

Tel: +358 (0)20 753 2500
parker.finland@parker.com

FR – France, Contamine s/Arve

Tel: +33 (0)4 50 25 80 25
parker.france@parker.com

GR – Greece, Piraeus

Tel: +30 210 933 6450
parker.greece@parker.com

HU – Hungary, Budaors

Tel: +36 23 885 470
parker.hungary@parker.com

IE – Ireland, Dublin

Tel: +353 (0)1 466 6370
parker.ireland@parker.com

IL – Israel

Tel: +39 02 45 19 21
parker.israel@parker.com

IT – Italy, Corsico (MI)

Tel: +39 02 45 19 21
parker.italy@parker.com

KZ – Kazakhstan, Almaty

Tel: +7 7273 561 000
parker.easteurope@parker.com

NO – Norway, Asker

Tel: +47 66 75 34 00
parker.norway@parker.com

PL – Poland, Warsaw

Tel: +48 (0)22 573 24 00
parker.poland@parker.com

PT – Portugal, Leca da Palmeira

Tel: +351 22 999 7360
parker.portugal@parker.com

RO – Romania, Bucharest

Tel: +40 21 252 1382
parker.romania@parker.com

RU – Russia, Moscow

Tel: +7 495 645-2156
parker.russia@parker.com

SE – Sweden, Spånga

Tel: +46 (0)8 59 79 50 00
parker.sweden@parker.com

SK – Slovakia, Banská Bystrica

Tel: +421 484 162 252
parker.slovakia@parker.com

SL – Slovenia, Novo Mesto

Tel: +386 7 337 6650
parker.slovenia@parker.com

TR – Turkey, Istanbul

Tel: +90 216 4997081
parker.turkey@parker.com

UA – Ukraine, Kiev

Tel: +48 (0) 22 572 24 00
parker.poland@parker.com

UK – United Kingdom, Warwick

Tel: +44 (0)1926 317 878
parker.uk@parker.com

ZA – South Africa, Kempton Park

Tel: +27 (0)11 961 0700
parker.southafrica@parker.com

North America

CA – Canada, Milton, Ontario

Tel: +1 905 693 3000

US – USA, Cleveland

Tel: +1 216 896 3000

Asia Pacific

AU – Australia, Castle Hill

Tel: +61 (0)2-9634 7777

CN – China, Shanghai

Tel: +86 21 2899 5000

HK – Hong Kong

Tel: +852 2428 8008

IN – India, Mumbai

Tel: +91 22 6513 7081-85

JP – Japan, Tokyo

Tel: +81 (0)3 6408 3901

KR – South Korea, Seoul

Tel: +82 2 559 0400

MY – Malaysia, Shah Alam

Tel: +60 3 7849 0800

NZ – New Zealand, Mt Wellington

Tel: +64 9 574 1744

SG – Singapore

Tel: +65 6887 6300

TH – Thailand, Bangkok

Tel: +662 186 7000

TW – Taiwan, Taipei

Tel: +886 2 2298 8987

South America

AR – Argentina, Buenos Aires

Tel: +54 3327 44 4129

BR – Brazil, Sao Jose dos Campos

Tel: +55 800 727 5374

CL – Chile, Santiago

Tel: +56 2 623 1216

MX – Mexico, Toluca

Tel: +52 72 2275 4200

European Product Information Centre

Free phone: 00 800 27 27 5374

(from AT, BE, CH, CZ, DE, DK, EE, ES, FI, FR, IE, IL, IS, IT, LU, MT, NL, NO, PL, PT, RU, SE, SK, UK, ZA)

EMEA Product Information Centre

Free phone: 00 800 27 27 5374

(from AT, BE, CH, CZ, DE, DK, EE, ES, FI, FR, IE, IL, IS, IT, LU, MT, NL, NO, PL, PT, RU, SE, SK, UK, ZA)

US Product Information Centre

Toll-free number: 1-800-27 27 537

