

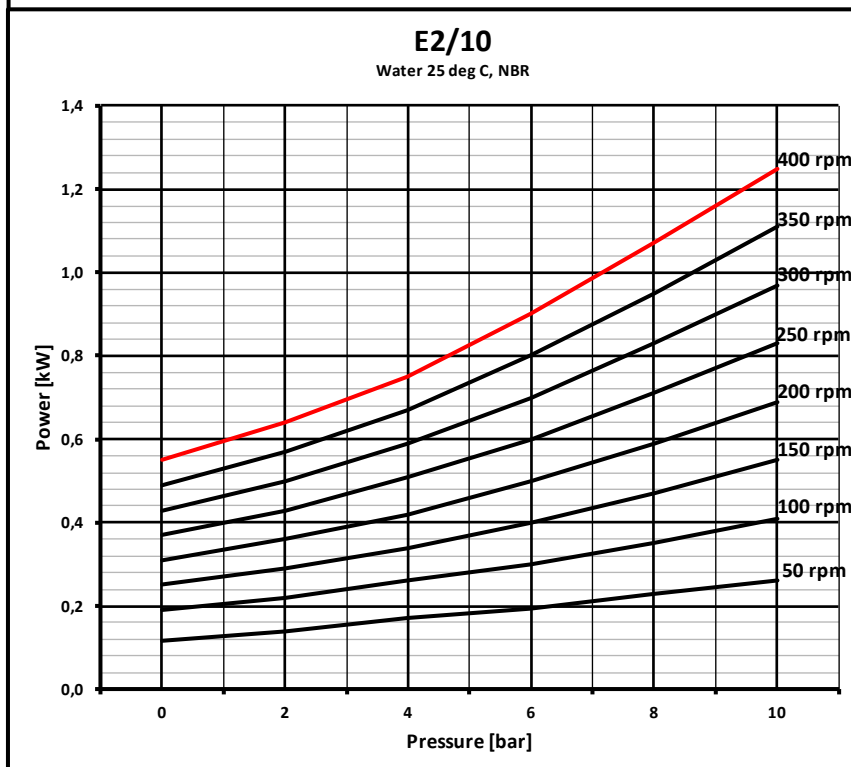

PC Pump E2/10

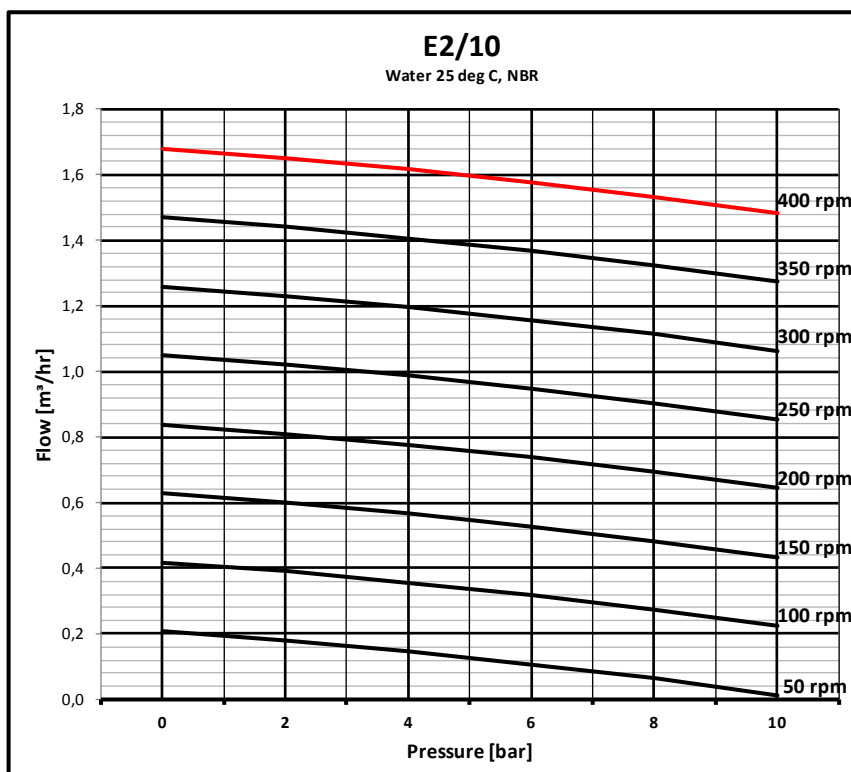

TECHNICAL DATA

- Evenwall® stator
- Maximum flow: 1,7 m³/h
- Nominal flow: 1,3 m³/h
- Maximum pressure: 10 bar
- Temperature up to 70 °C
- Weight: 110 kg
- Max motor power: 1,5 kW
- Flange connection size: DN50
- Flange drilling: DIN PN10 or ANSI150
- Can be installed without base plate
- No dry running
- NPSH tba

MAIN DIMENSIONS

Model	A	B	C	D	E	F	G	H	I	J	K	L	M	Weight (kg)
E2/10	1260	433	229	423	368	128	125	14	240	165	508	290	35	110

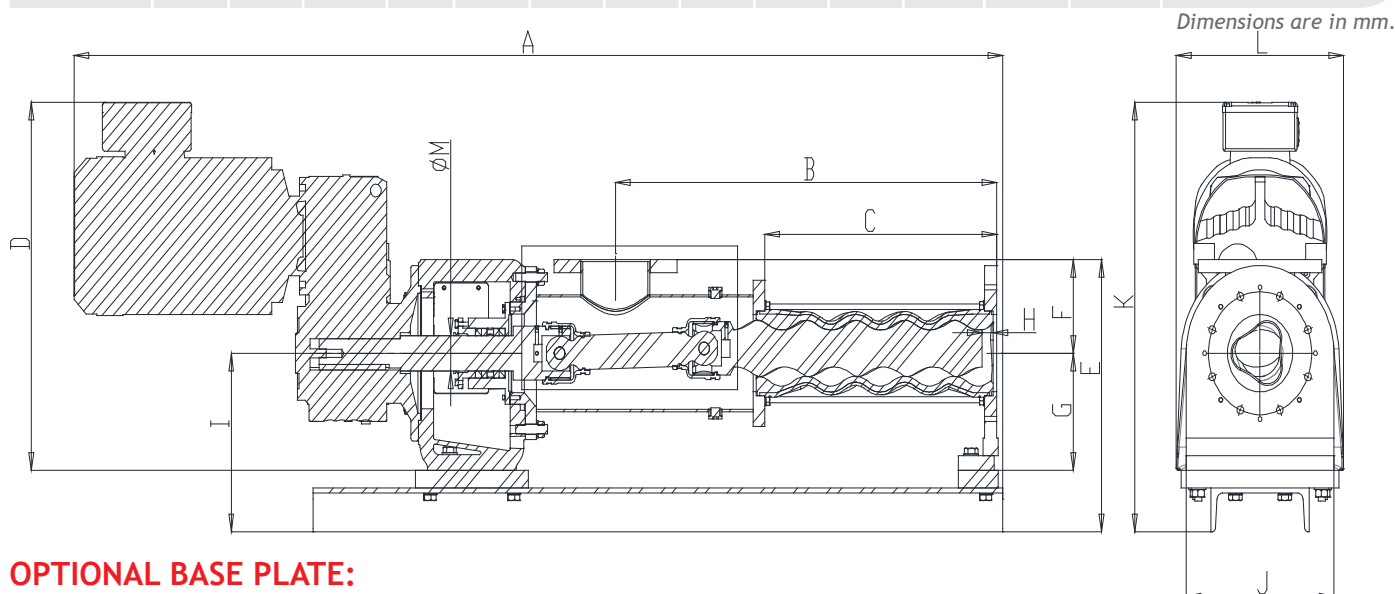

OPTIONAL BASE PLATE:

Model	N	O	P	Q	R	S	T	U	V	W	X
E2/10	940	45	226	60	226	60	589	80	220	150	160

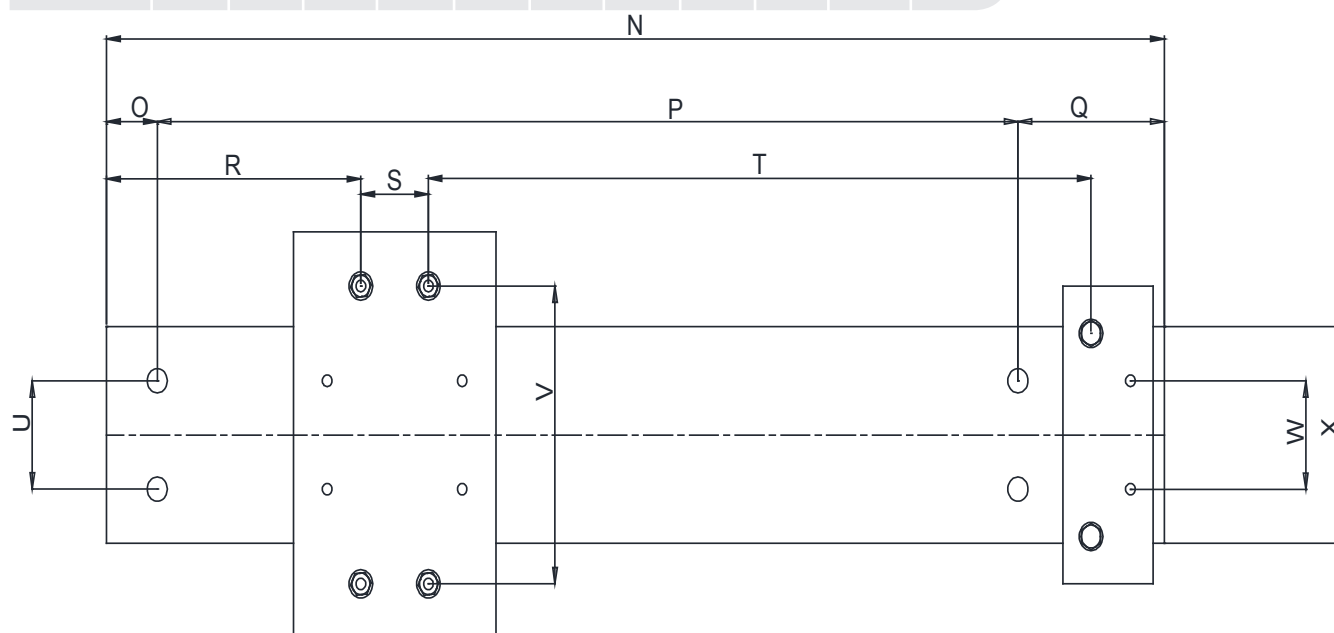

PRODUCT SPECIFICATION

Body	Suction Pipe	Rotor	Rotor coatings	Stator	Drive	Seal types
Cast iron	<ul style="list-style-type: none"> Carbon steel Carbon steel with maintenance hatch Stainless steel with maintenance hatch 	<ul style="list-style-type: none"> Carbon steel Stainless steel 	<ul style="list-style-type: none"> Black nitrated Hard chromium Tungsten carbide 	<ul style="list-style-type: none"> NBR EPDM Viton 	Gear motor drive	<ul style="list-style-type: none"> Single Mechanical Shaft Seal Double Mechanical Shaft Seal Gland Packing

Information without engagement. All rights to changes without prior notice reserved.



Flowrox Oy
P.O. Box 338, FI-53101 Lappeenranta
Finland
Tel. +358 201 113 311

www.flowrox.com
info@flowrox.com

