

 CAREX[®] Segmentblock system
for sealing of conveyor belt transfers



CAREX® Segmentblock system



A good sealing system between feeding chute and belt is a „must“ for a dust controlled conveyor belt transfer. The sealing should be easy to mount and individually adjustable and regulate. Belts always sag between the idlers and wear the sealing most above the idlers.

They are retained by a rear backing plate and at the front side by, adjustable counter plate and are sealed with each other by tongue and groove. Blows from a hammer will adjust it so that only a light belt contact will occur and the critical gap is tightened.

That's why single CAREX® Segmentblocks are used instead of the usually continuous, clamped rubber sealing strips.

CAREX® Segmentblocks are an approved and professional solution to your problems direct at the transfer as well as for all lateral guidings.

Specification:

Segmentblock systems for sealing of conveyor belt transfer against the belt with backing plates, counter plates, with fixing set and individually adjustable segmentblocks.

Backing plates: 150 x 1000 x 2 mm
Steel galvanised, 2,3 kg

Segment blocks: 200 x 155 x 18 mm, 0,74 kg

Type N: 55° Shore A ($\pm 5^\circ$), relatively oil resistant, excellent ozone and wearing resistant quality, black

Type NBR: as before, food quality, light beige

You need for each running meter: one Backing plate
5 Blocks
5 Counter plates

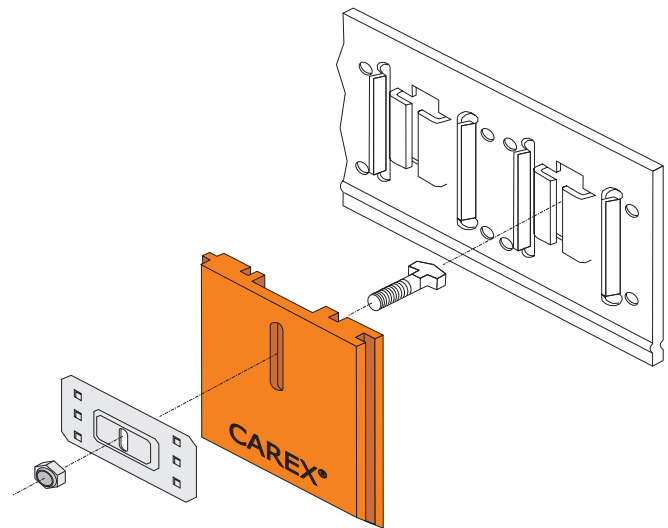

Sizes:

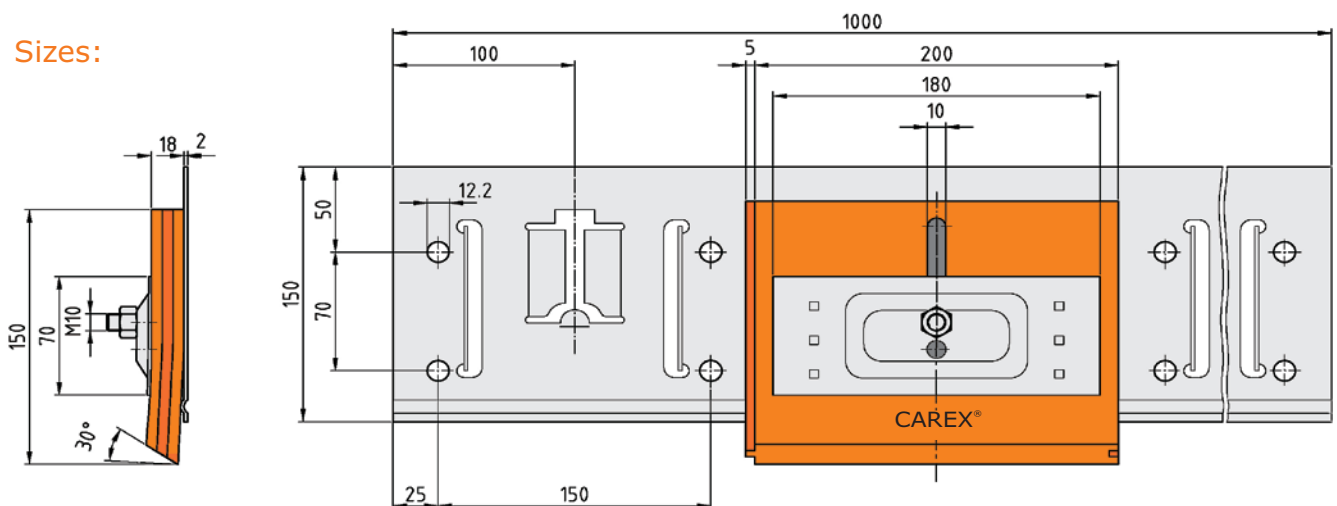

CAREX[®] Segmentblock system

Advantages

- Low installation height

A clear installation height of 160 mm is sufficient. The segmentblocks are put on and fixed from the front and not inserted into the guiding from above.

- Lateral fixing

The blocks cannot be pressed out of the rubber by a belt drifting to the sides, as they are retained by the screwed counter plates.

- Easy adjustability

The counter plates are equipped with tongues standing out being squeezed into the rubber so that the blocks can be easily adjusted downwards but cannot be forced back by the belt.

- Variable clamping

The pressure and thus the clamping effect of the counter plates can be modified by self-locking nuts. Thus the vertical adjusting force can be regulated.

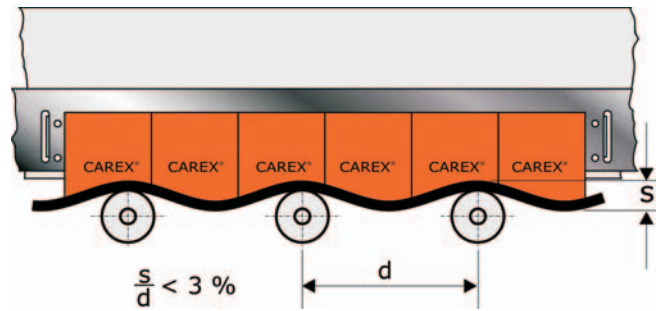
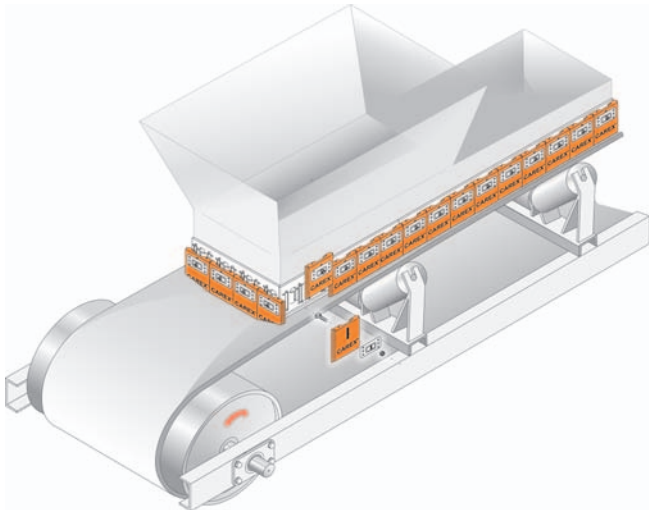

CAREX[®] adapts itself to the belt contour.

- Good running-in behaviour

A 30° bevelling at the lower edge allows a good running-in and sealing behaviour right from the beginning.

- High lifetime

The blocks are made from rubber or plastic. They have a high life time and are kind to the belt, as the hardness is the same or even lower than the degree Shore of the belt. The adjusting length amounts to 60 mm.

- Simple mounting

The mounting of the backing plates is quick and simple. The fixing is done by stitch welding, screwing or blind riveting. The blocks can also be hung into the backing plates by anchor bolts. They can be exchanged individually.

- Possible pre-mounting

The mounting is particularly quick when the blocks are already pre-mounted onto the backing plates and the lower edge of the backing plate is left open. After having welded the edge, the blocks are hit down and the upper edge is then welded.

Mounting exemple:

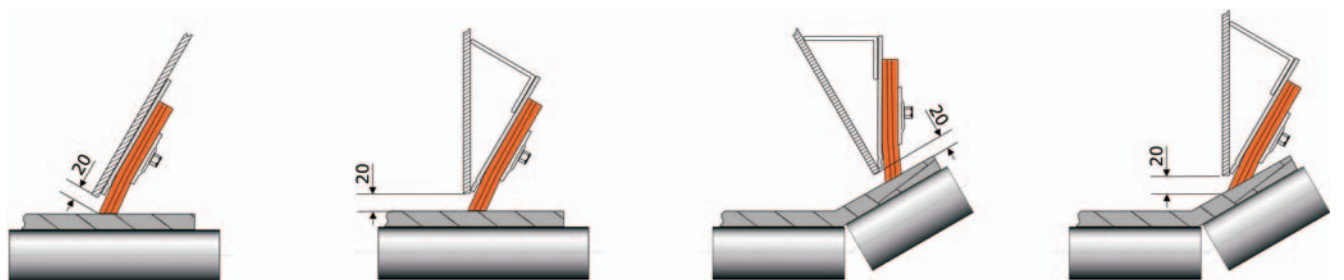

The CAREX[®] systems make dirty transfers to clean and low cost transfer stations

Product programme

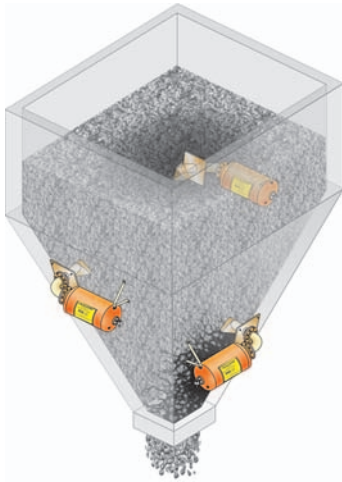

VSR BLASTER® Air cannons and air injectors

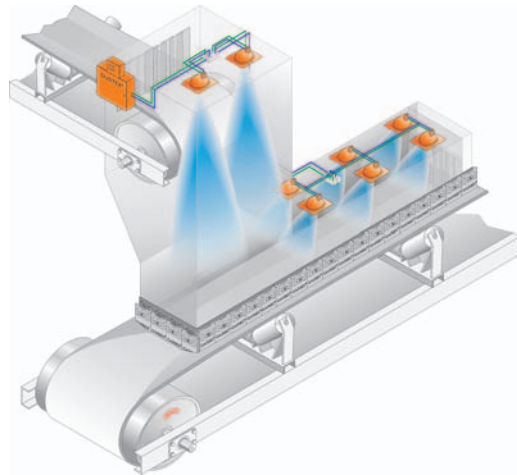

DUSTEX® Dust suppression system

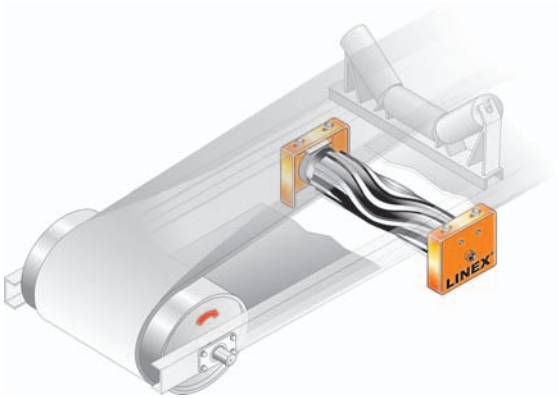

LINEX® Conveyor belt centralizing idler

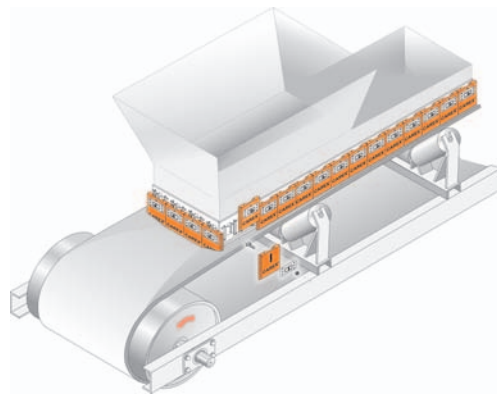

CAREX® sealing of conveyor belt transfers

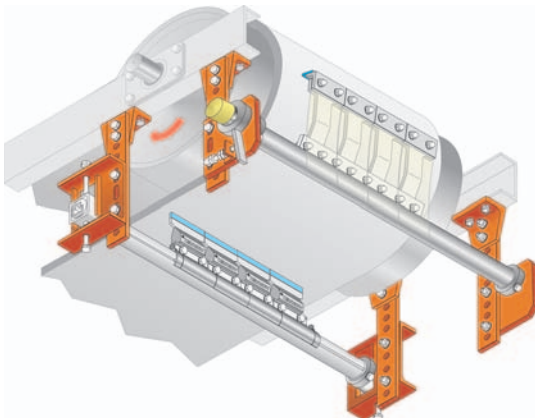

VIBREX® Conveyor belt cleaning

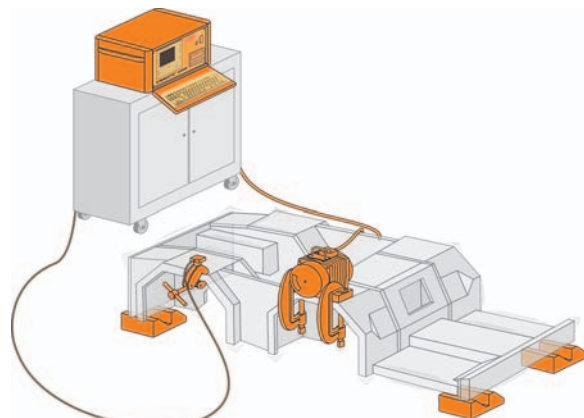

VIBMATIC 6000® Vibration stress reduction

VSR



VSR Industrietechnik GmbH
Am Alten Schacht 6
D- 47198 Duisburg
Tel. +49 (0) 20 66 / 99 66-30
Fax +49 (0) 20 66 / 99 66-62

Internet: www.vsr-industrietechnik.de

E-mail: info@vsr-industrietechnik.de