



VIBREX<sup>®</sup> Conveyor Belt Cleaner



## VIBREX<sup>®</sup> Conveyor belt cleaner

### The right choice

#### Dirt

... immense, day by day. Many tons are spread over large areas and on the conveyor belt construction, obstructing the regular material flow. At worst, important equipment is destroyed. This results in loss of production and high costs.

#### Cleaning

There is no universal cleaner with the same, good effect for all applications. The VIBREX<sup>®</sup>-kit system allows to deliver the optimal scraper type for the individual solution of your cleaning problem within a short time.

#### Service

Conveyor belt cleaners work under extreme conditions, for the most part in continuous operation. VIBREX<sup>®</sup>-Cleaners consist of a few, type-compatible components. They are robust, quickly to mount and easy to adjust respectively to maintain. On request, our specialized personnel is always at your disposal. Please ask for our reasonable rates.

#### Costs

Long service life of the cleaning elements ensure low maintenance costs and guarantee a permanent and reliable effect. By applying VIBREX<sup>®</sup>-Conveyor belt cleaners, you will reduce costs that could result from missing or badly working cleaners.

**Dirty conveyor belt transfers  
will become clean transfer points**

# VIBREX® Conveyor belt cleaner

## The right type

...at the drum

Front cleaner  
Type PRAKTIK

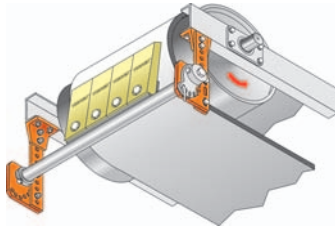

polyurethane  
blades

Front cleaner  
Type CLIP

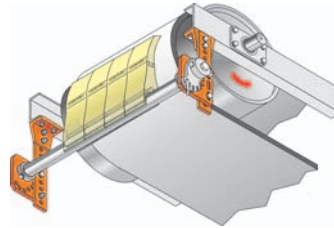

polyurethane  
blades

Head cleaner  
VXK 100

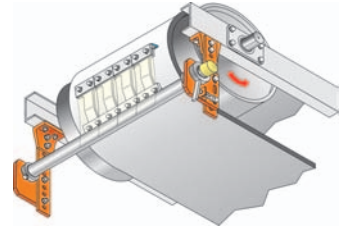

hard metal  
blades

...under the  
lower belt

Spring blade cleaner  
Type Clip / Fix

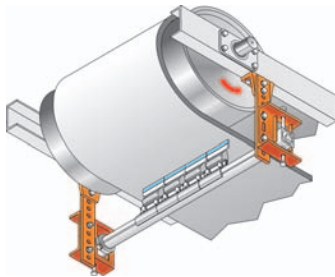

hard metal  
blades

Main cleaner  
Type Clip / Fix

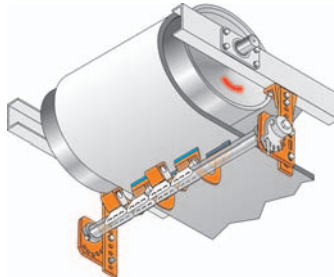

hard metal  
blades

Cleaning brush

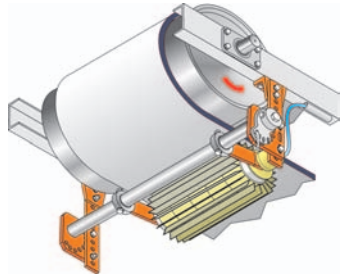

polyurethane  
elements

...on the  
lower belt

Plough cleaner

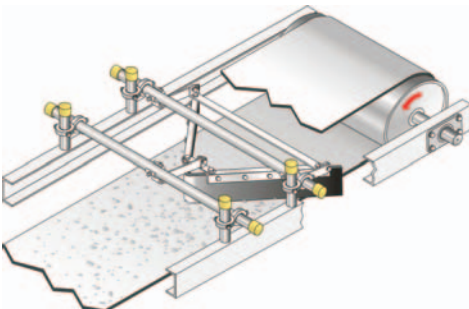

multilayer rubber

Transversal cleaner

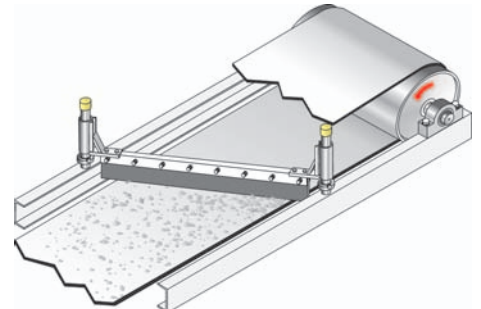

multilayer rubber

... for belt widths of 400 up to 2000 mm

# Product programme

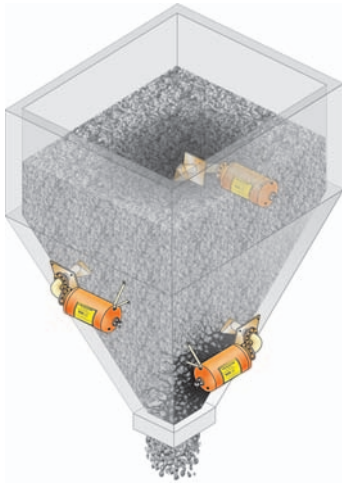

VSR BLASTER® Air cannons and air injectors

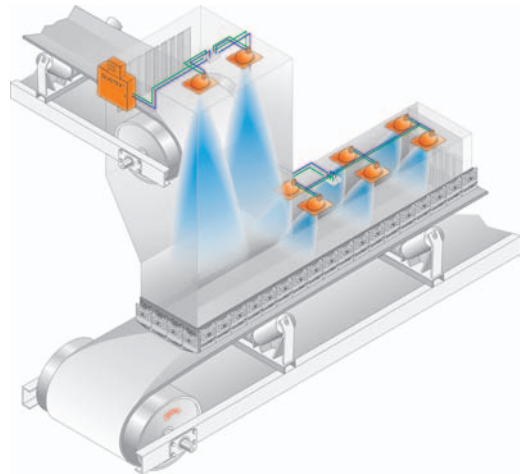

DUSTEX® Dust suppression system

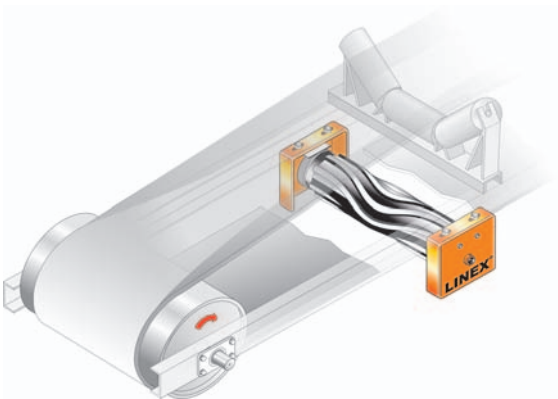

LINEX® Conveyor belt centralizing idler

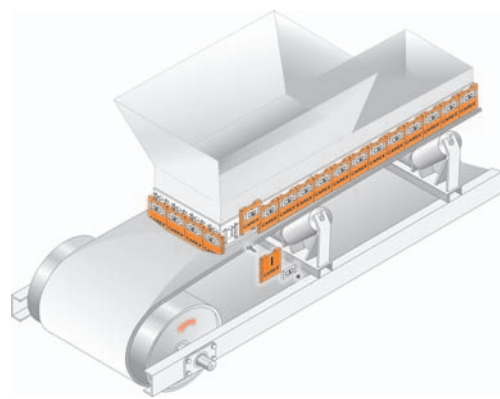

CAREX® sealing of conveyor belt transfers

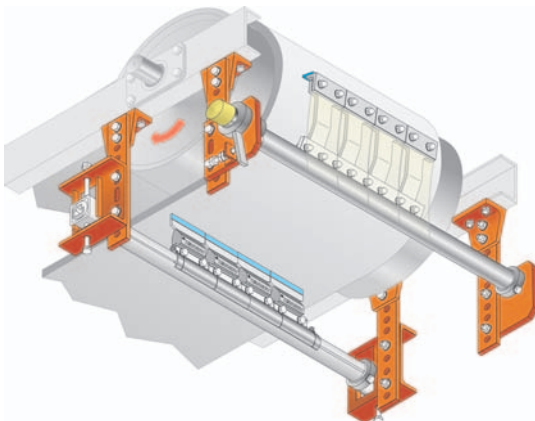

VIBREX® Conveyor belt cleaning

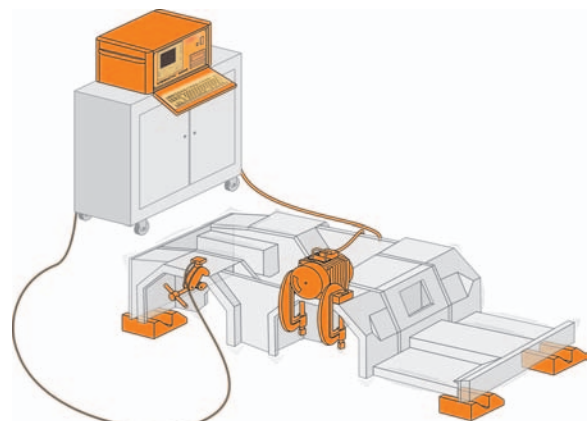

VIBMATIC 6000® Vibration stress reduction

# VSR



Internet: [www.vsr-industrietechnik.de](http://www.vsr-industrietechnik.de)

VSR Industrietechnik GmbH  
Am Alten Schacht 6  
D- 47198 Duisburg  
Tel. +49 (0) 20 66 / 99 66-30  
Fax +49 (0) 20 66 / 99 66-62

E-mail: [Info@vsr-industrietechnik.de](mailto:Info@vsr-industrietechnik.de)